

**HOW
DOES
THE
ANS
WORK?**

GETTING THE MESSAGE ACROSS

Chemical Messengers of the ANS: An Introduction

The autonomic nervous system works by releasing messenger chemicals inside the body. These chemicals act on receptors on target cells, such as heart muscle cells, and this changes body functions.

The chemical messengers of the autonomic nervous system are the neurotransmitters, acetylcholine and norepinephrine, and the hormone, adrenaline.

Acetylcholine is the chemical messenger of the parasympathetic nervous system (PNS), the sympathetic cholinergic system (SCS), and the somatic nervous system. Norepinephrine is the chemical messenger of the sympathetic noradrenergic system (SNS), and adrenaline is the chemical messenger of the sympathetic adrenergic system (SAS).

The transmission of chemicals in the autonomic nervous system (neurotransmission) involves a few common steps, although there are some important variations on the theme.

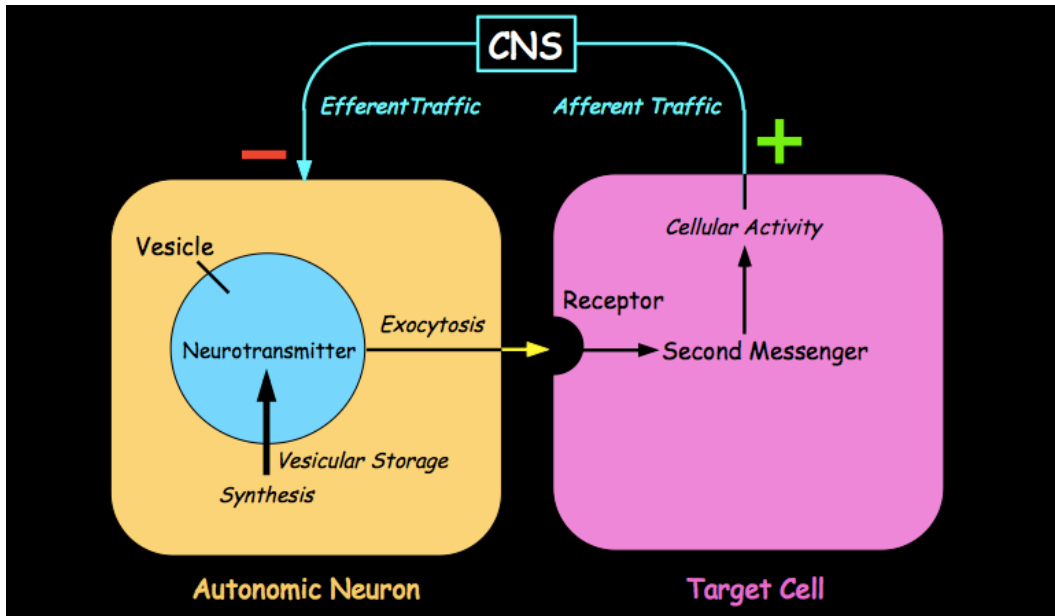

Some common themes in how autonomic nerves work.

First of all, acetylcholine, norepinephrine, and adrenaline are stored in tiny bubble-like structures called vesicles. In the cases of acetylcholine and adrenaline, the chemical messengers are produced in the cytoplasm (“cell juice”) and then are actively pumped into the vesicles. In the case of norepinephrine, the chemical messenger is produced within the vesicles.

The neurotransmitter is released by exocytosis, where the vesicle moves to the cell membrane surface of the cell, a hole forms at the junction of the vesicle and cell membrane, and the messenger makes its way out of the cell. Microscopically, there is a little “omega sign.”

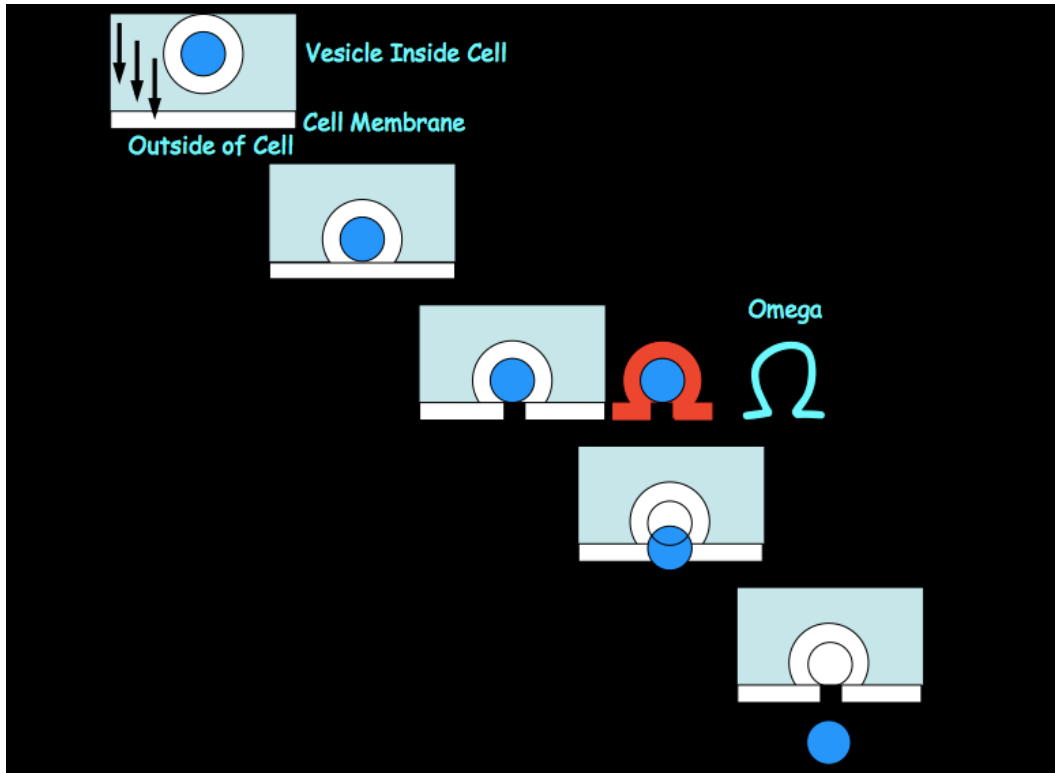

Exocytosis, the process of neurotransmitter release

Third, the chemical messenger, sometimes called a “first messenger,” reaches specific receptors on the target cells. For instance, acetylcholine released from parasympathetic nerves in the heart binds to cholinergic receptors, causing the heart rate to decrease.

Fourth, occupying the receptors leads to “second messengers” in the target cells, changing the activity of the cells.

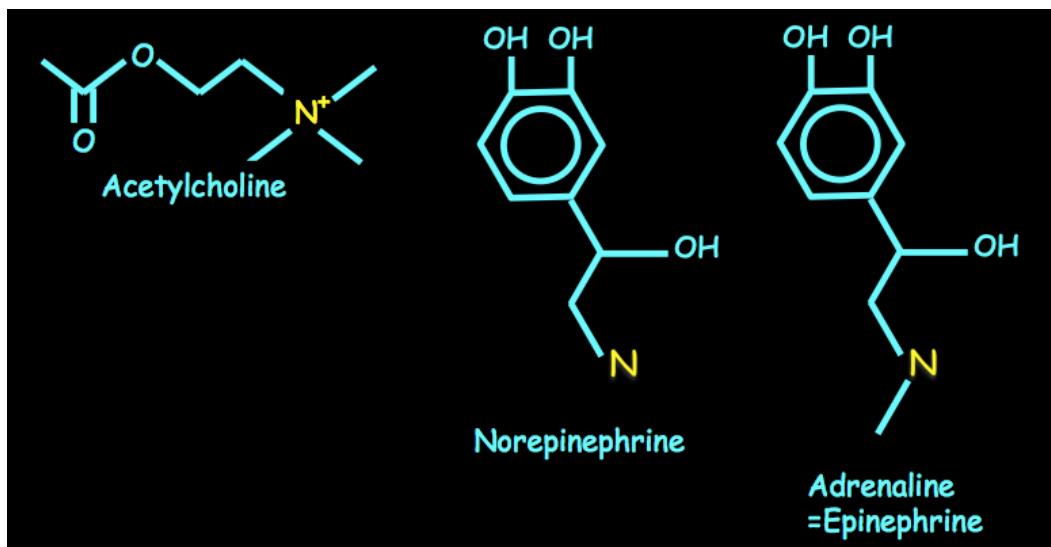

*Chemical messengers of the autonomic nervous system
acetylcholine, norepinephrine, and adrenaline (epinephrine)*

Fifth, activation of target cells alters information traveling to the central nervous system, and reflexive changes in traffic in the autonomic nerves complete a negative feedback loop. Because of the negative feedback loop, the release and effects of the neurotransmitter are kept stable.

Acetylcholine, norepinephrine, and adrenaline are small molecules. They contain a prominent, single nitrogen (N) atom—a quaternary ammonium ion in acetylcholine and an amine group in norepinephrine and adrenaline. They are basic, meaning that at a neutral pH they are positively charged. And they are actively taken up into and stored in

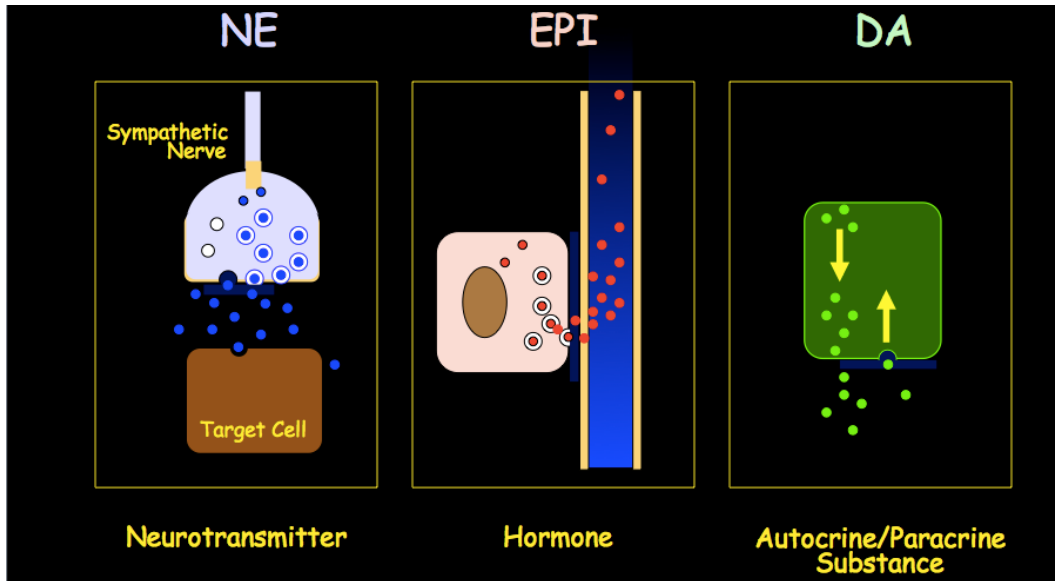

Three types of chemical messengers—neurotransmitters, hormones, and autocrine/paracrine substances

vesicles, which have a relatively acidic pH.

For example, when you exercise on a hot day, activation of a part of the autonomic nervous system (the sympathetic cholinergic system) releases acetylcholine, a chemical messenger, from the nerve terminals, activating receptors on the cells of sweat glands. Activation of the receptors causes the glands to release sweat.

Automatic systems of the body use three types of chemical messengers.

There are three types of chemical messengers that can be released in your body. The first type of chemical messenger is released from nerves. Chemicals released from nerves are called neurotransmitters. Neurotransmitters act locally and are also inactivated locally. This means that only a relatively small amount of released neurotransmitter makes its way to the bloodstream unchanged.

Two of the main neurotransmitters of the autonomic nervous system are norepinephrine and acetylcholine. Small amounts of norepinephrine are detectable in the plasma, and measurement of plasma norepinephrine is a common test in the evaluation of dysautonomias thought to involve the sympathetic noradrenergic system.

On the other hand, acetylcholine released from nerves of the parasympathetic nervous system and from nerves of the sympathetic cholinergic system is so rapidly and efficiently broken down that normally acetylcholine is not detectable in the plasma. Therefore, tests of the parasympathetic and of the sympathetic cholinergic system rely on other types of measurements.

The second type of chemical messenger is released directly into the bloodstream. This type of messenger is called a hormone.

One of the most famous hormones is adrenaline, which is released

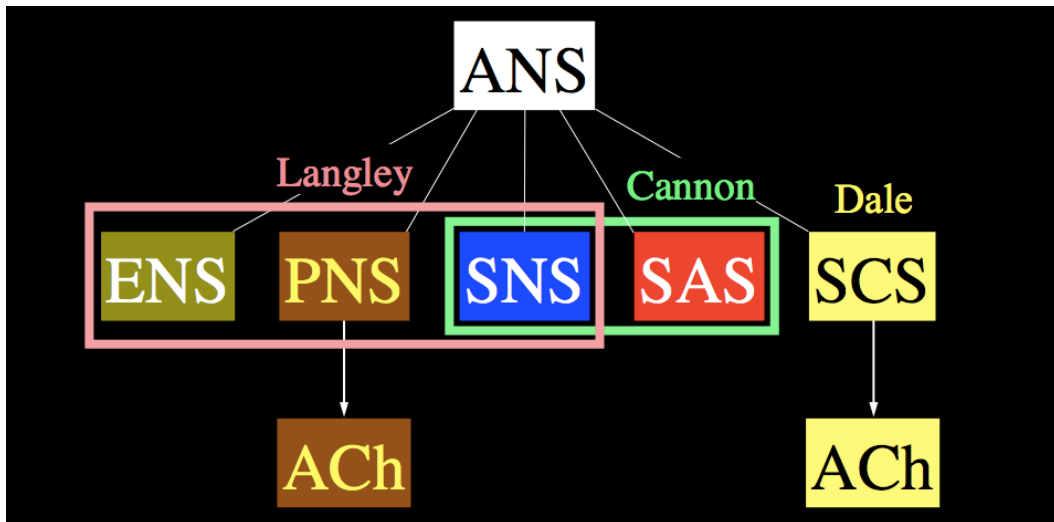

Acetylcholine is the chemical messenger of the parasympathetic nervous system (PNS) and the sympathetic cholinergic system (SCS).

into the bloodstream by the adrenal gland. Hormones are delivered by way of the bloodstream to all organs of the body.

The third type of chemical messenger is probably the oldest in terms of evolution but newest in terms of recognition by scientists. The chemicals are called autocrine/paracrine substances. The chemical messengers are made in, released from, and act on the same or nearby target cells within the tissue.

Autocrine/paracrine substances are released just about as soon as they

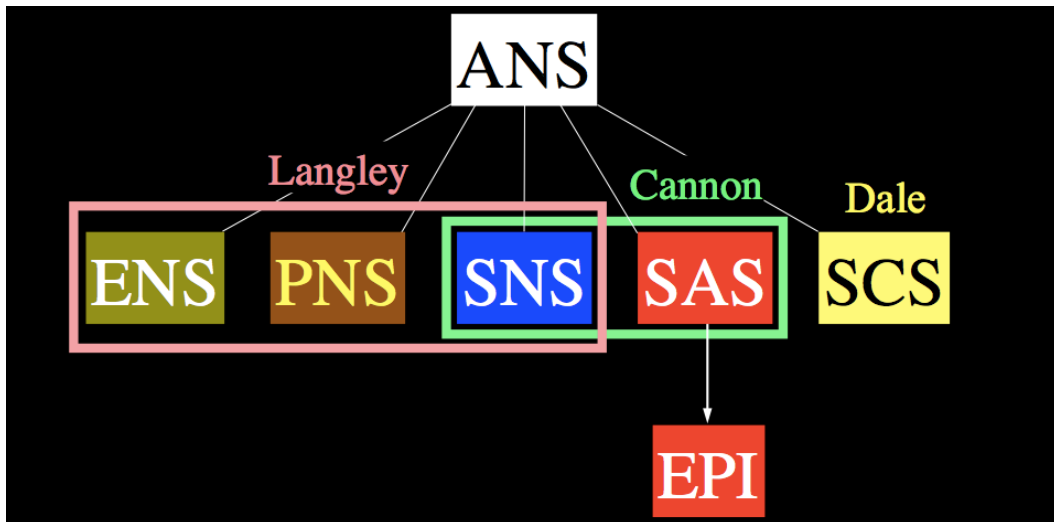

Adrenaline, or epinephrine (EPI), is the chemical messenger of the sympathetic adrenergic system (SAS).

are made within the cells, unlike hormones and neurotransmitters, which are stored at particular sites within cells and are released from the storage sites in response to nerve traffic. Of several autocrine/paracrine substances in the body, one is the chemical, dopamine. Loss of dopamine terminals in a particular pathway largely determines the movement disorder that characterizes Parkinson disease. Dopamine produced as an autocrine- paracrine substance in the kidneys plays a role in regulation of salt and water balance.

The parts of the autonomic nervous system have particular chemical messengers.

The chemical messenger of the parasympathetic nervous system (PNS) is acetylcholine, and the PNS is cholinergic. Otto Loewi discovered acetylcholine, the first identified neurotransmitter. For this discovery he received a Nobel Prize.

Acetylcholine released from parasympathetic nerves produces many effects in the body, including increasing the tone of the urinary bladder and bowel, increasing gastric acid secretion, stimulating salivation and tear production, and decreasing the heart rate.

Acetylcholine is important for “vegetative” activities like salivating, digesting, and getting rid of waste.

Acetylcholine is also the neurotransmitter of the sympathetic cholinergic system (SCS). Acetylcholine release from sympathetic cholinergic nerves acts at sweat glands, causing perspiration. Sweating responses have been classified as thermoregulatory (such as sweating when exercising in the heat), gustatory (sweating mainly on the forehead after eating, especially chili peppers), and emotional.

Acetylcholine is also important for sweating.

Norepinephrine (NE), the neurotransmitter of the sympathetic noradrenergic system (SNS) plays a major role in regulation of the heart and blood vessels during many activities of daily life.

Epinephrine (EPI), or adrenaline, the main chemical messenger of the sympathetic adrenergic system (SAS), is crucial for maintaining organismic integrity in response to overall challenges such as hypoglycemia, hypothermia, hemorrhagic hypotension, anoxia, and emotional distress. EPI produces prominent cardiovascular effects. Probably the effect occurring at the lowest concentration is relaxation of blood vessels in skeletal muscle, so that skeletal muscle and total peripheral resistance to blood flow decrease. Heart rate increases.

Because of constricting blood vessels in the skin, adrenaline produces pallor. EPI is also one of the three hormones regulating blood glucose levels (the others are insulin and glucagon) and is probably responsible for the hyperglycemia attending emergencies. EPI activates platelets and thereby helps minimize traumatic blood loss. Since EPI generates calories and constricts cutaneous blood vessels, core temperature tends to increase. The combination of cutaneous vasoconstriction and EPI-induced sweating probably explains the “cold sweat” in shock.

The bloodstream delivers adrenaline throughout the body.

The last chemical messenger of the autonomic nervous system to be identified was norepinephrine (NE), or noradrenaline. This was in the mid-1940s, by the Swedish physiologist U.S. von Euler. For this discovery von Euler received a Nobel Prize.

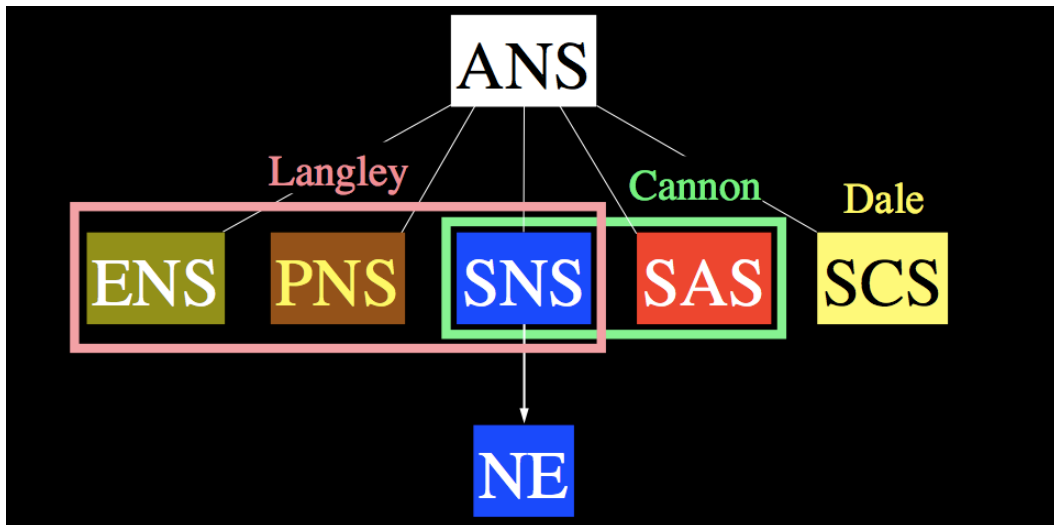

Norepinephrine (NE) is the chemical messenger of the sympathetic noradrenergic system (SNS), the main part of the sympathetic nervous system involved with regulation of the heart and blood vessels.

Norepinephrine is the main chemical messenger of the sympathetic nervous system that is responsible for regulation of the cardiovascular system. The “SNS” in this schema refers specifically to the sympathetic noradrenergic system, in distinction from the sympathetic adrenergic system and the sympathetic cholinergic system.

Norepinephrine is the main chemical messenger, or neurotransmitter, of the sympathetic nervous system in regulation of the heart and blood vessels.

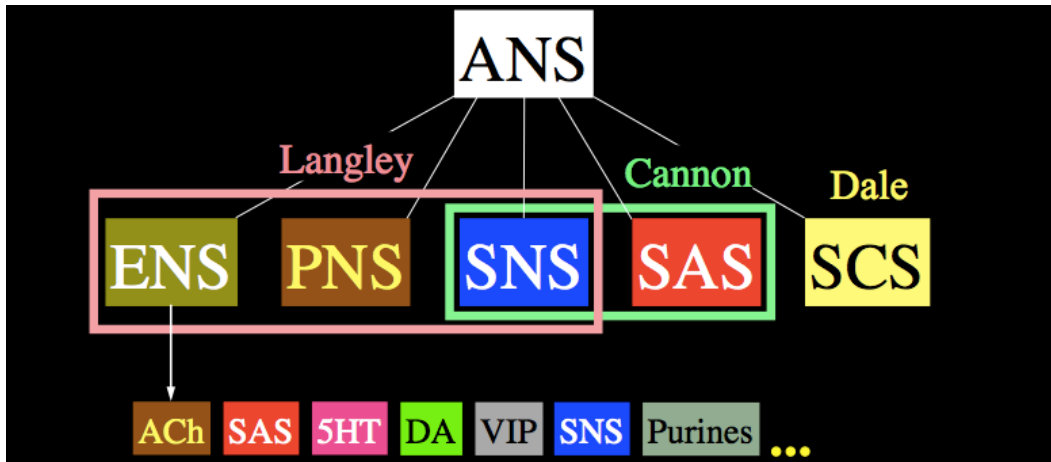

The enteric nervous system (ENS) involves many neurotransmitters.

You will be learning a lot about the chemical family that includes norepinephrine (noradrenaline), epinephrine (adrenaline), and dopamine. The chemical family is the catecholamines.

There is no single neurotransmitter of the enteric nervous system. Most of the serotonin and dopamine made in the body are produced in the ENS. Acetylcholine is another enteric neurotransmitter, and there are many others.

The Search for the Omega Sign

Once produced in the vesicles in autonomic nerves, neurotransmitters



Thomas Renton Elliott, a student of Langley, proposed the concept of chemical neurotransmission.

are released from the nerve terminals by a process called exocytosis.

Exocytosis is the key element in the theory of chemical neurotransmission, first proposed by Thomas Renton Elliott in 1904. Elliott was a student of Langley, the same Langley who coined the phrase, “autonomic nervous system.”

Elliott had noted that stimulation of sympathetic nerves and injection of adrenal gland extract produced similar effects in the body. In a stroke of genius, he hypothesized that the similarity resulted from a chemical like adrenaline actually being released from the nerves and acting on nearby cells. His brief note published in the *Journal of Physiology* proposed “a mechanism developed out of the muscle cell,

in response to its union with the synapsing sympathetic fibre, the function of which is to receive and transform the nervous impulse. Adrenalin(e) might then be a chemical stimulant liberated on each occasion when the impulse arrives at the periphery.”

It took until the early 1920s for experimental proof of this concept to emerge, and the scientist who provided that proof, Otto Loewi, received a Nobel Prize in 1936 for his discovery of the first neurotransmitter, acetylcholine. It was not until much later that scientists considered how neurotransmitters actually are released from nerves. Only within the last couple of decades has it been demonstrated that adrenaline in sympathetic nerves can be released by sympathetic nerve stimulation.

The theory of exocytosis is fairly simple to state but has proven devilishly difficult to test. According to the theory chemical neurotransmission results from physical movement of the bubble-like vesicles containing the neurotransmitter toward the cell membrane, fusion of the vesicle membrane with the cell membrane, pore formation at the site of fusion of the two membranes, and entry of the contents of the vesicles into the fluid outside the cell. Among those contents is the neurotransmitter, which diffuses a short way to reach receptors on the membrane of the target cells.

One of the ways to test the theory of exocytosis would be by direct visualization. If the vesicle membrane actually fused with the cell

membrane, and a hole formed at their junction, then if one looked under an electron microscope at the nerve terminal, one should see little “omega signs” or see the vesicle contents coming through the cell membrane. Only relatively recently has this type of direct visualization come about by highly sophisticated techniques. A very small percentage of vesicles are actually found poking their way through the membrane surface.

Pretty Woman

Acetylcholine is produced from the action of an enzyme, choline acetyltransferase (ChAT), on choline and acetyl coenzyme A in the cytoplasm. The enzyme catalyzes the transfer of the acetate ion to choline. The acetylcholine (ACh) is then actively taken up into vesicles by a transporter (the vesicular acetylcholine transporter, or VACHT).

After release of acetylcholine by exocytosis into the extracellular fluid, the transmitter can bind to specific receptors on target cells. It is also rapidly broken down by an enzyme called acetylcholinesterase (AChE), which regenerates the acetate and choline. Because of the rapid breakdown of acetylcholine by AChE, it is impossible to monitor activity of the cholinergic neurons by measuring levels of acetylcholine in body fluids such as plasma or urine.

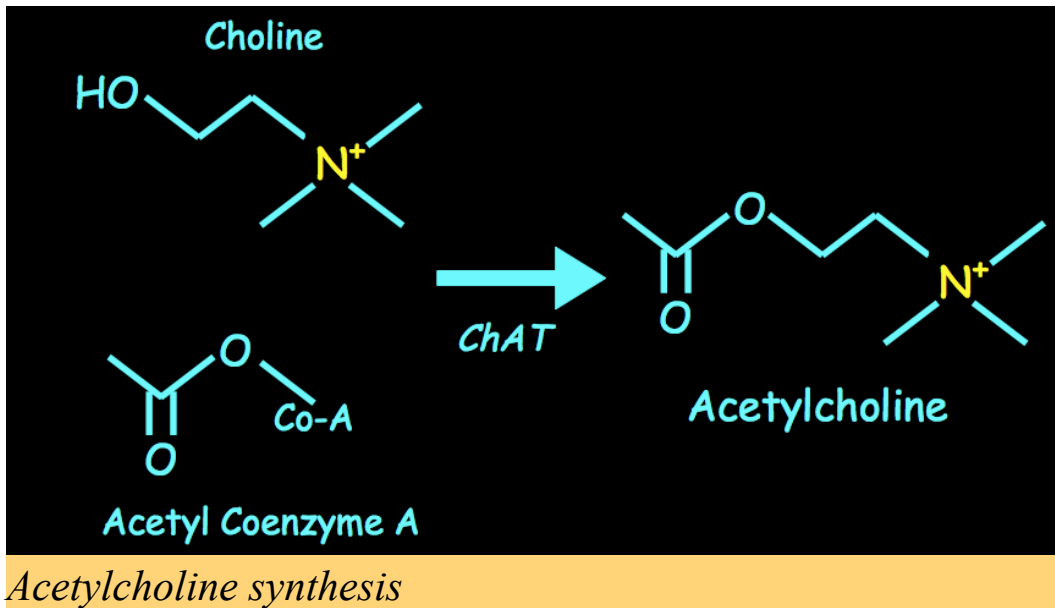

Blockade of effects of the parasympathetic nervous system on the pupils causes the pupils to dilate.

According to tradition, Italian women used to instill in their eyes a product of the root of a plant in the genus *Atropa*, out of the belief that the drug-induced dilation of the pupils would make them more attractive. The extract came to be called “belladonna,” meaning “pretty woman.” In fact the full taxonomic name of the plant is *Atropa belladonna*.

A less appealing appellation for the same plant is “deadly nightshade.” Every part of the plant is poisonous, and atropine overdose can be lethal.



Atropine, derived from the plant, Atropa belladonna, dilates the pupils.

The word, *Atropa*, is derived from the Greek *Atropos*, one of the Fates. *Atropos* held the shears that could cut the thread of human life.

CATECHOLS LOOK LIKE CATS

I'm an admitted catecholaholic. I'd like to explain why—and why anyone interested in dysautonomias should join the “catecholamine club.”

Two of the most important parts of the autonomic nervous system use members of the catecholamine (pronounced cat-a-COLA-mean) family as the main chemical messengers.

The sympathetic noradrenergic system (SNS) is responsible for regulation of the heart and blood vessels and key body functions such as blood pressure. The main chemical messenger of the SNS is norepinephrine (NE). The sympathetic adrenergic system (SAS) is responsible for helping keep you live in emergencies, such as shock from gastrointestinal hemorrhage. The main chemical messenger of the SAS is adrenaline (synonymous with epinephrine, EPI).

Measuring levels of catecholamines and related chemicals is a key part of the workup of patients with dysautonomias.

Later on we will be going in depth about the many ways clinical catecholamine neurochemistry is important for diagnosis, understanding disease mechanisms, and treatment of dysautonomias. Catecholamines also are the only chemical messengers of the

autonomic nervous system that can be measured in body fluids such as the plasma, urine, or spinal fluid. By assaying levels of catecholamines and their breakdown products, one can gain insights into the diagnosis of patients with complaints referable to the autonomic nervous system.

Drugs that affect the production, release, or inactivation of catecholamines or that work by stimulating or blocking receptors for catecholamines are mainstays in the treatment of various forms of dysautonomia.

Virtually every dysautonomia and every treatment for dysautonomias involves catecholamines directly or indirectly.

The Nobel Chemicals

Catecholamine research has led to many Nobel Prizes.

Discoveries based on catecholamine research relate directly to regulation and dysregulation of the inner world by the autonomic nervous system and development of several novel, successful, rational treatments for major diseases. This section presents some of these discoveries together, to present briefly ideas that receive more attention elsewhere, providing a kind of summary for this long

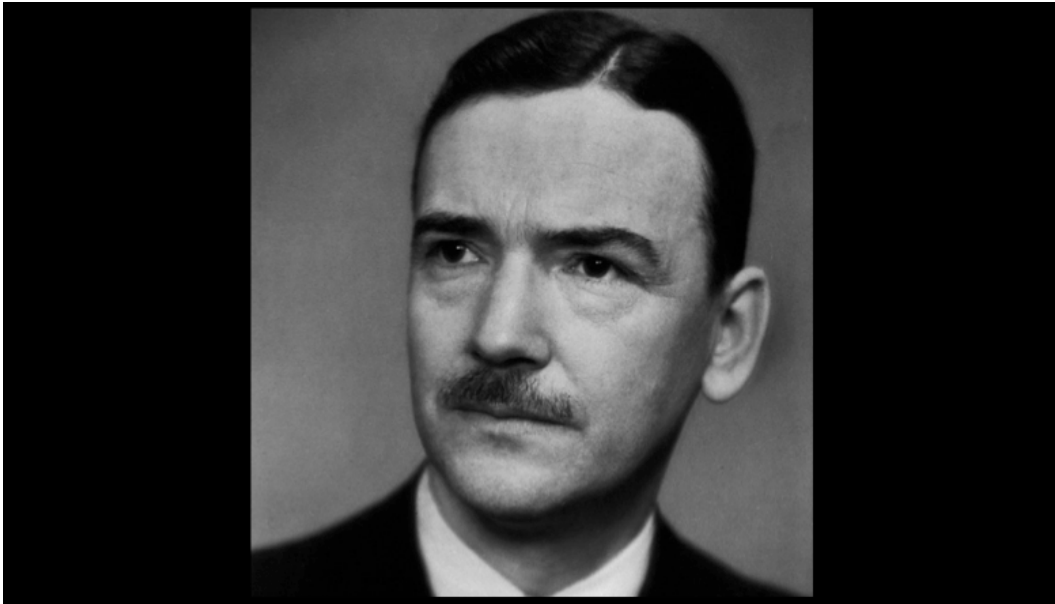

U.S. von Euler (Nobel Prize, 1970) identified norepinephrine as the neurotransmitter of the sympathetic nervous system.

chapter and affirming the continuing importance of catecholamine systems in science and medicine.

After Ahlquist's 1948 suggestion that there were two types of adrenoceptors, alpha and beta, researchers worldwide directed their attention to the molecular structures of adrenoceptor, the mechanisms that link occupation of the receptors at the surface of the target cells to processes inside those cells, and development of novel treatments for diseases, based on drugs that block or stimulate adrenoceptors. For the development of beta-adrenoceptor blockers, Sir James Black

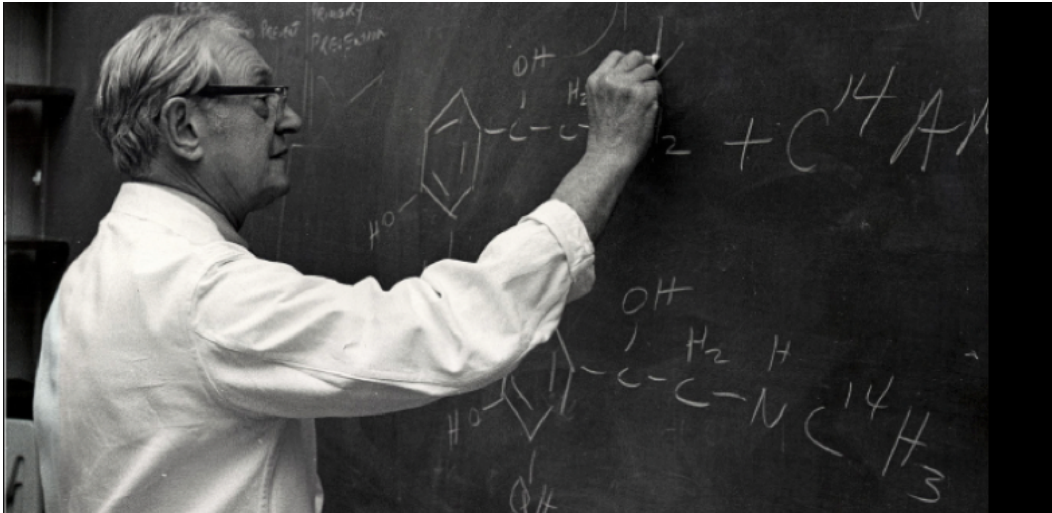

Julius Axelrod (Nobel Prize, 1970) discovered neuronal reuptake as a route of catecholamine inactivation.

shared a Nobel Prize in 1988.

Discoveries related to the mechanisms determining cellular activation after adrenoceptor occupation have led to at least three other Nobel Prizes.

For the discovery of G-proteins, Alfred G. Gilman and Martin Rodbell shared a Nobel Prize in 1994. For the discovery of cAMP, the first identified intracellular messenger, E. W. Sutherland received a 1971 Nobel Prize. For the discovery of phosphorylation as a key step in the activation or inactivation of cellular processes, Edmond H. Fischer and Edwin G. Krebs shared a 1992 Nobel Prize.

After release of norepinephrine from sympathetic nerves, the



Rita Levi-Montalcini (Nobel Prize, 1986) discovered nerve growth factor, which sympathetic nerves require.

norepinephrine undergoes inactivation mainly by a conservative recycling process, in which sympathetic nerves take up norepinephrine from the fluid bathing the cells--a process called uptake-1. Once back inside the nerve cells, most of the norepinephrine undergoes uptake back into storage vesicles.

Julius Axelrod's studies about the disposition of catecholamines introduced the idea that termination of the actions of some neurotransmitters depends on neuronal reuptake. Axelrod shared a Nobel Prize with U. S. von Euler in 1970. As noted above, von Euler received the Nobel Prize for identifying norepinephrine as the neurotransmitter of the sympathetic nervous system.



Sir James W. Black (Nobel Prize, 1988) developed a class of catecholamine receptor blockers.

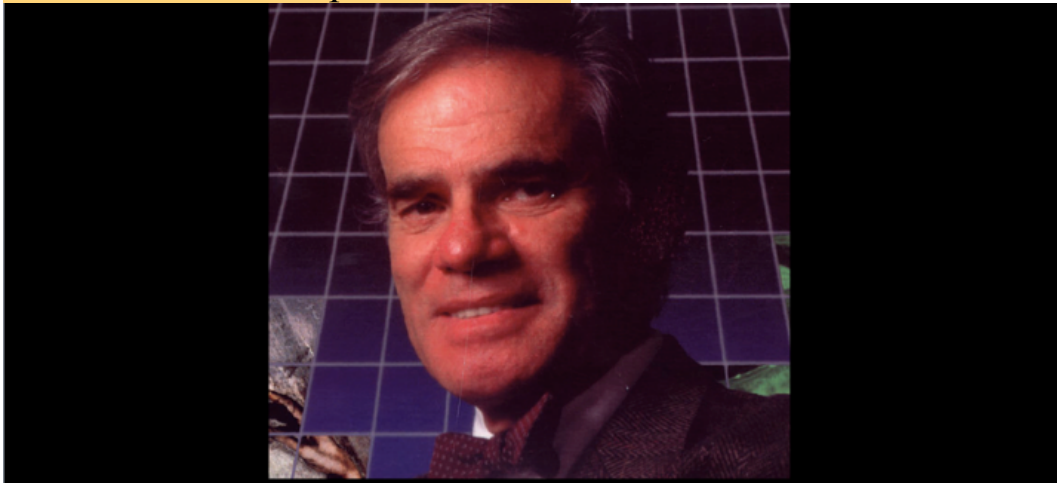

Martin Rodbell (shown here) and Alfred G. Gilman shared a 1994 Nobel Prize for discovering G-proteins.



Paul Greengard (Nobel Prize, 2000) discovered slow transmission of signals after dopamine binds to its receptors.

Release of norepinephrine in response to traffic in sympathetic nerves traffic of course depends on the existence of functional sympathetic nerve terminals. The development and continued existence of sympathetic nerves in an organ depend in turn on a continuous supply of a nerve growth factor. The discovery of nerve growth factor arose importantly from studies of sprouting of nerve filaments from sympathetic ganglia cells. For discovering the first known neurotrophic factor, Stanley Cohen and Rita Levi-Montalcini shared a 1986 Nobel Prize.



Arvid Carlsson (Nobel Prize, 2000) discovered that dopamine is a neurotransmitter in the brain.

Arvid Carlsson and Paul Greengard shared a Nobel Prize in 2000. Both these scientists focused on the “third catecholamine,” dopamine. Until about the 1950s, dopamine had been assumed not to have any specific function in the body beyond serving as a chemical intermediary in the production of adrenaline and norepinephrine. Carlsson discovered that dopamine in the brain acts as a neurotransmitter in its own right and is of great importance in regulation of movement. Loss of dopamine in a particular pathway in the brain produces the movement disorder defining Parkinson disease, and replenishment of dopamine by administration of its precursor, L-DOPA, results in rapid improvement in movement. Carlsson also



Robert Lefkowitz discovered G-protein coupled receptors by studying catecholamine receptors. Brian Kobilka identified genes encoding catecholamine receptors. They shared the 2012 Nobel Prize in Chemistry.

demonstrated that effective drugs to treat schizophrenia work by blocking dopamine receptors in the brain.

Greengard discovered that communication between nerve cells mediated by catecholamines takes place by a relatively slow, diffuse process, called slow synaptic transmission, which probably underlies phenomena such as mood and vigilance and also modulates fast synaptic transmission, as in speech, movement, and sensation.

The most recent Nobel Prize for catecholamine research was awarded

in 2012 to Robert Lefkowitz and Brian Kobilka, for their discoveries about catecholamine receptors (adrenoceptors) and more generally about a class of receptors, which include adrenoceptors, that function by coupling to G-proteins. Lefkowitz isolated beta-adrenoceptors, and Kobilka identified the genes that encode types of beta-adrenoceptors.

Cannon's Ingenious Experiment

To identify and quantify adrenaline release during stress, beginning in about 1919 Walter B. Cannon developed and over the next two decades exploited an ingenious experimental setup. He would surgically excise the nerves supplying the heart of a laboratory animal such as a dog or cat. Then he would subject the animal to a stressor such as one of those listed above and record the heart rate response. With the nerves to the heart removed, he could conclude that if the heart rate increased in response to the perturbation, then the increase in heart rate must have resulted from the actions of a hormone. Finally, he would compare the results in an animal with intact adrenal glands with those in an animal from which he had removed the adrenal glands. From the difference in the heart rate between the two animals, he could infer further that the hormone responsible for the increase in heart rate came from the adrenal glands. Moreover, the amount of increase in the heart rate provided a measure of the amount of

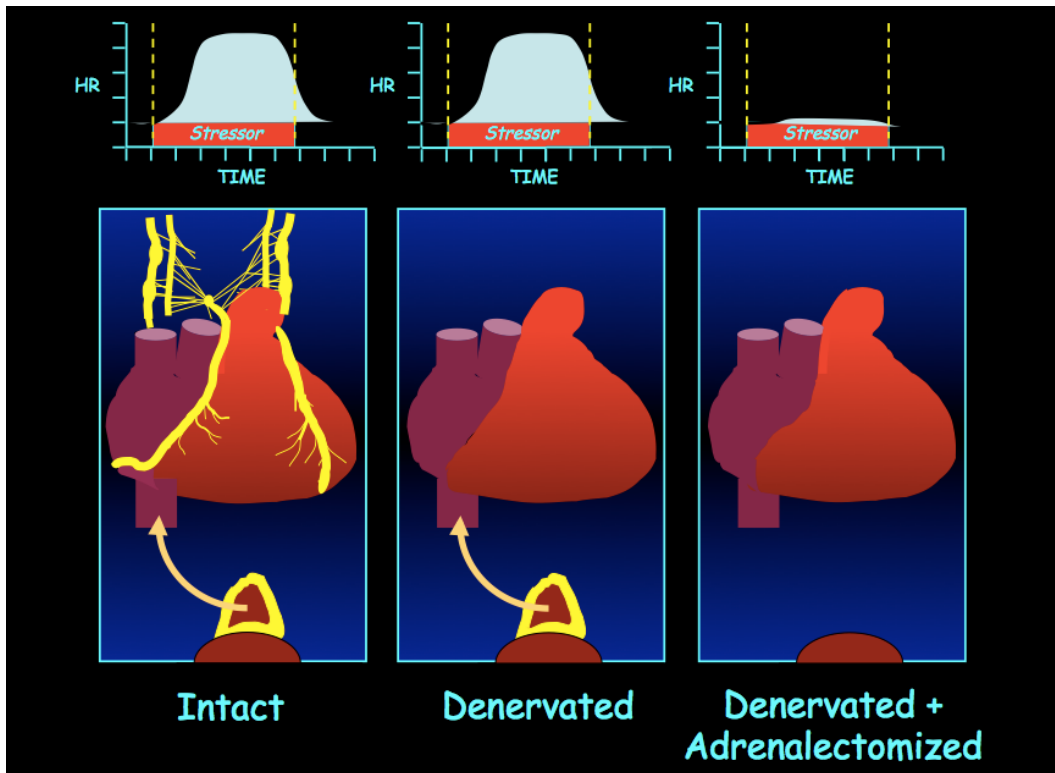

Walter B. Cannon used an ingenious denervated heart preparation to measure adrenaline release in response to different stressors.

hormone released.

Because cutting the sympathetic nerves to the heart was an integral part of the experimental setup, Cannon could not appreciate the contribution of those nerves to regulation of the heart's functions. The experimental design also prevented him from recognizing that

disabling one component of the sympathoadrenal system would activate the other compensatorily.

The notion spread afterward that the sympathoadrenal system is active only in emergencies. In fact, the parasympathetic nervous system, by way of release of its neurotransmitter, acetylcholine, works in a dynamic balance with the sympathetic noradrenergic system, by way of release of its neurotransmitter, norepinephrine, to modulate the rate of the heartbeat, even in people at rest. Levels of adrenaline in the bloodstream, however, have not been found to correlate with resting heart rate.

Why Catechols Look Like Cats

Members of the adrenaline family are catecholamines, and catecholamines are catechols.

The chemical, catechol, has a particular structure, consisting of a hexagon of carbon atoms with hydroxyl (OH) groups attached to adjacent points of the hexagon. Catechol itself does not exist in the human body, but chemicals that contain catechol as part of their molecular structure are called catechols.

One way to remember what catechols look like is to picture their structure as the head of a cat.

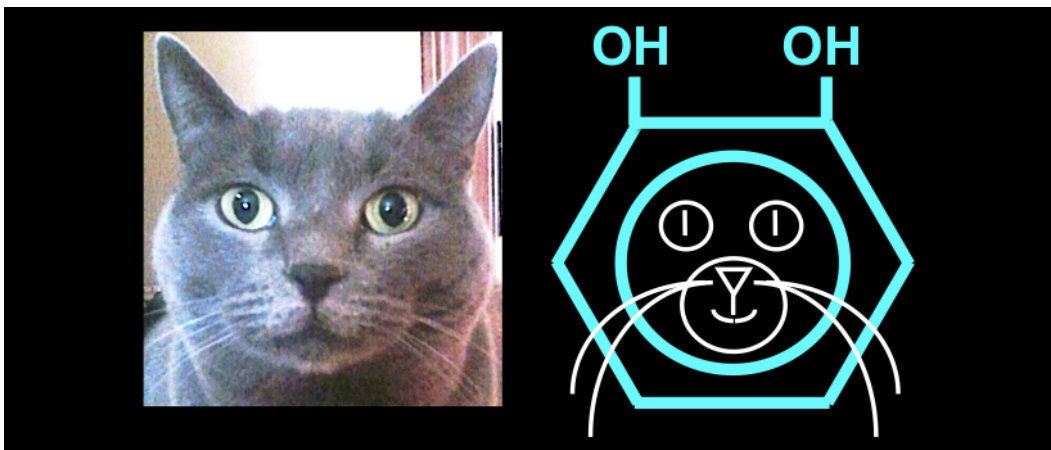

The chemical structure of catechol looks like a cat's head.

The hexagonal ring is the face. The two hydroxyl groups are the pointy ears.

Catecholamines look like the entire cat, including its tail. The tail of the cat is a short hydrocarbon strand, consisting of carbon and hydrogen atoms. At the end of the tail is an amine (ammonia) group. Think of a cat in its litter box, with the ammonia coming off the tail end producing a smell like urine.

Human plasma contains several catechols. Three are the catecholamines, adrenaline, norepinephrine, and dopamine. Another catechol is L-DOPA, the same chemical that, as a drug, is used to treat Parkinson disease. Two other catechols are breakdown products—metabolites—of the catecholamines. 3,4-

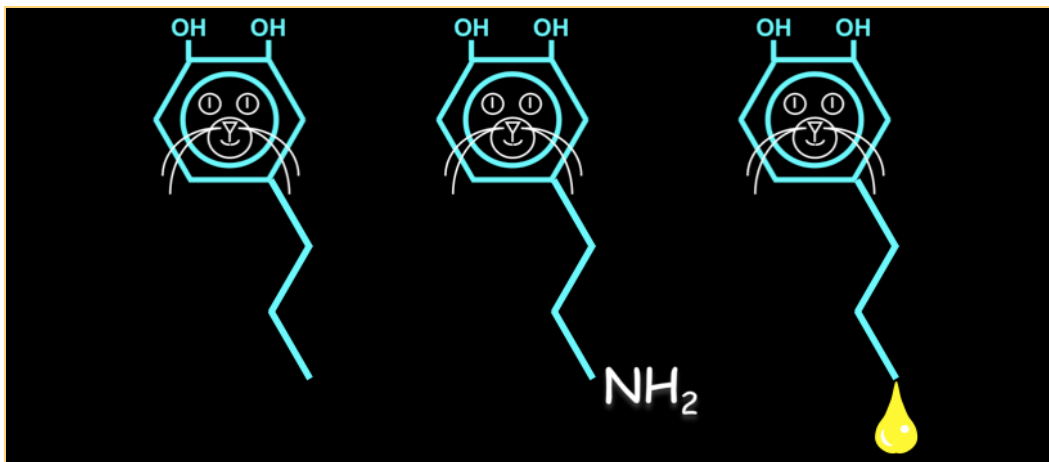

Catecholamines look like the entire cat, from head to tail.

dihydroxyphenylglycol (DHPG) is a metabolite of norepinephrine and adrenaline, and 3,4-dihydroxyphenylacetic acid (DOPAC) is the main metabolite of dopamine in dopamine nerves.

The body's three catecholamines, dopamine, norepinephrine, and adrenaline, are like the grandfather, father, and son in a small chemical family. Adrenaline is derived from norepinephrine, and norepinephrine is derived from dopamine.

The three catecholamines happen to represent the three different ways the body regulates the inner world of the body. Adrenaline is a hormone, released from the adrenal gland into the bloodstream and then swept by the bloodstream to organs and tissues throughout the body, where adrenaline produces a large variety of effects.

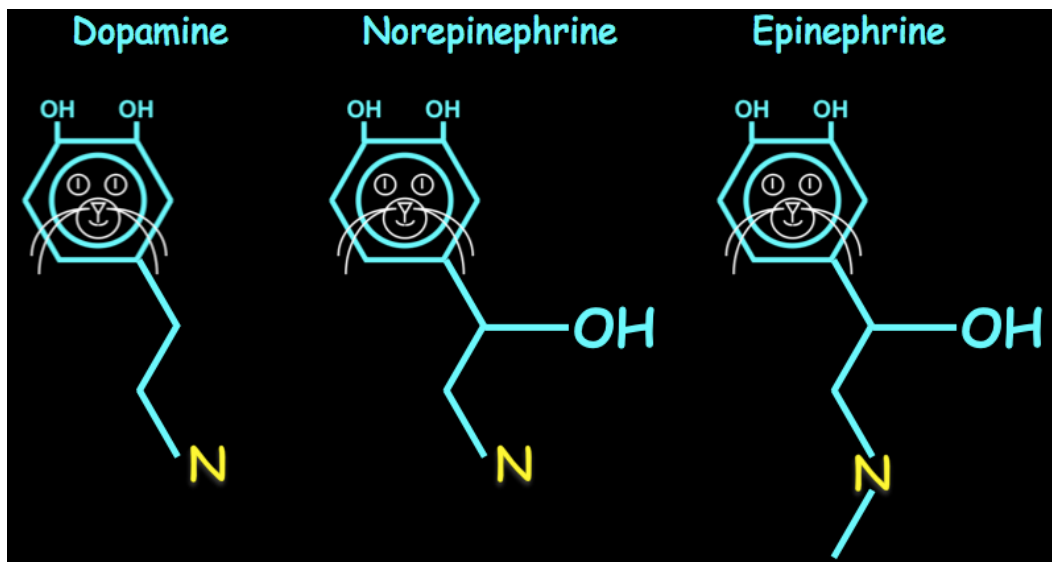

Dopamine, norepinephrine, and epinephrine (adrenaline) are catecholamines.

Norepinephrine is a neurotransmitter, released from nerves of the sympathetic nervous system and acting mainly locally on nearby target cells. Although a small proportion of the norepinephrine released from sympathetic nerves enters the bloodstream, norepinephrine in the bloodstream must reach relatively high concentrations before it exerts effects as a hormone.

Outside the brain, dopamine appears to be an “autocrine-paracrine” substance, produced in, released from, and acting locally on the same type of cells. Concentrations of dopamine in these organs have little to do with local nerves. In evolutionary terms, dopamine systems

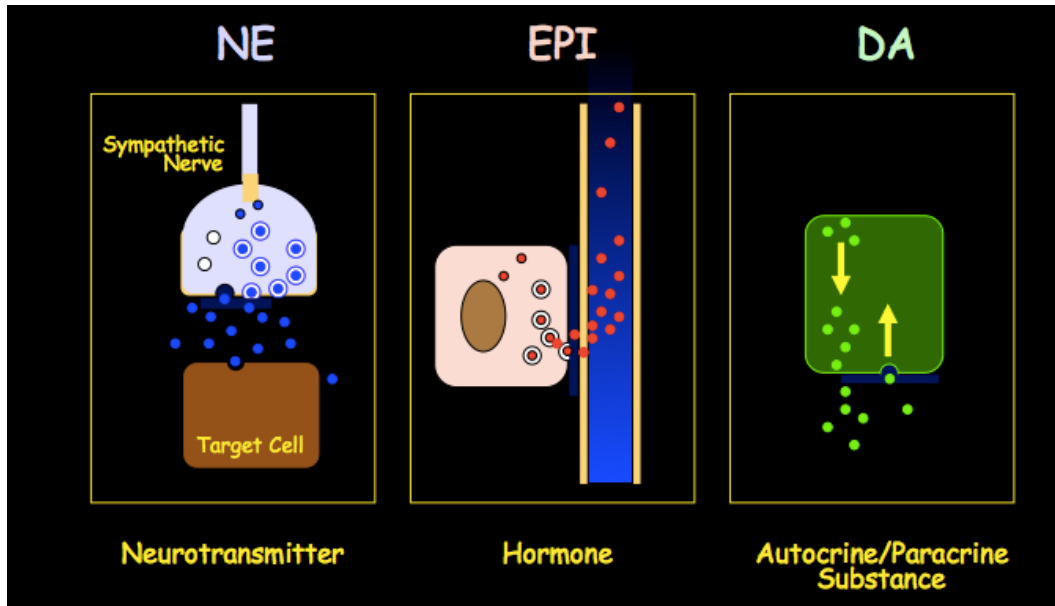

Norepinephrine is a neurotransmitter, epinephrine is a hormone, and dopamine (outside the brain) is an autocrine-paracrine substance.

seem to date from before the time of nerve networks or hormones. As will be seen, in nerves of the sympathetic noradrenergic system (SNS) dopamine is converted to norepinephrine, the main chemical messenger of the SNS.

Within the brain, dopamine is an important neurotransmitter. The discovery that dopamine is a neurotransmitter in the brain led to a Nobel Prize in 1970 for Arvid Carlsson. Norepinephrine is also a neurotransmitter in the brain. Norepinephrine is synthesized

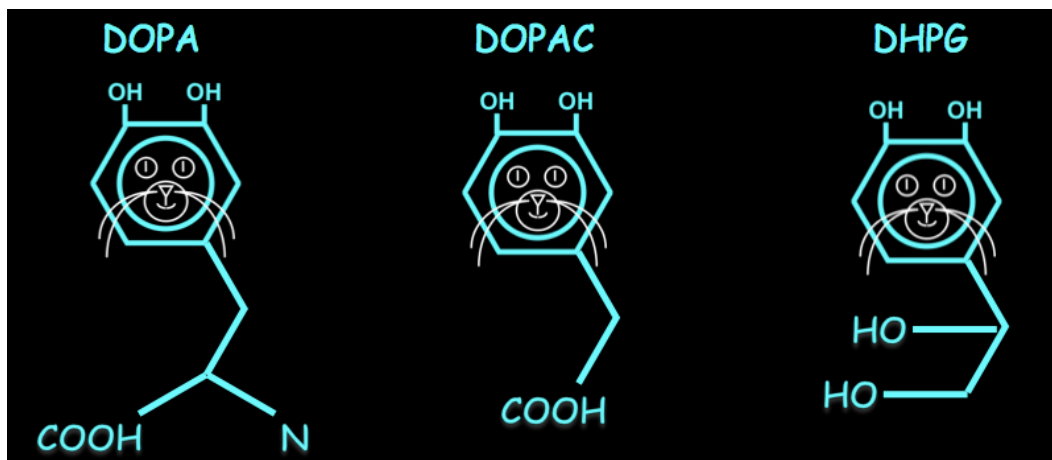

Other catechols normally found in the plasma include DOPA, DOPAC, and DHPG.

from dopamine after dopamine uptake into a particular type of vesicles.

Neuronal Soda Pop

This section describes the stations on the catecholamine assembly line—the steps in catecholamine biosynthesis.

To people with Parkinson disease, DOPA (also called L-DOPA and levodopa), the key component of Sinemet™, is a miracle drug. Within minutes, DOPA converts a shuffling, tremulous, slow-moving person with head bowed to a vigorous, upright, normally moving person with head held erect.

I will never forget the first time I witnessed this phenomenon, while I was a medical student. At the beginning of the lecture, the professor introduced a patient with Parkinson disease who had not yet taken DOPA that day. Slowly, unsteadily, and with help the patient made his way up the steps of the amphitheater and exited the doors at the top. He took his DOPA outside. At the end of the lecture the professor reintroduced him. The patient literally bounded down the steps, and when he reached the lectern he turned around swiftly to the assembled students, a broad grin on his face. The audience erupted in applause.

The body's catecholamines come from DOPA.

All three of the body's catecholamines come from DOPA, and the DOPA comes from tyrosine, an amino acid. Amino acids are the building blocks of proteins. Tyrosine is an amino acid that is not a catechol. Tyrosine is converted to DOPA by the actions of an enzyme (a protein that speeds up a particular chemical process). The enzyme that speeds up the conversion of tyrosine to DOPA is tyrosine hydroxylase.

For tyrosine hydroxylase to work requires oxygen, iron, and tetrahydrobiopterin, abbreviated BH_4 . BH_4 is a very important co-factor.

Deficiency of enzymes required to produce BH_4 can produce a pediatric neurodegenerative disease or else a particular movement

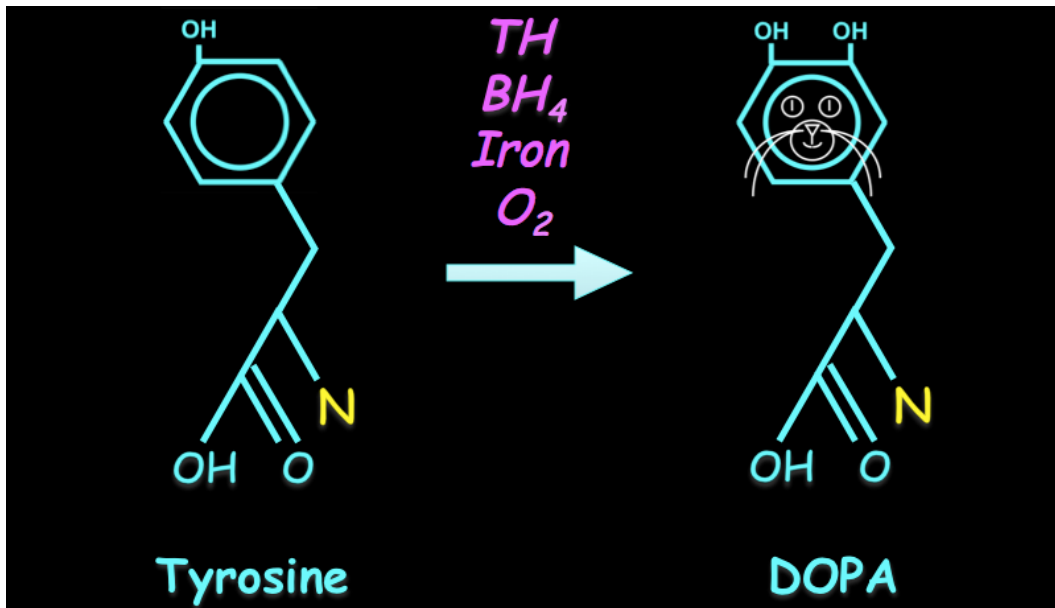

The first step in catecholamine synthesis is conversion of tyrosine to the catechol amino acid, DOPA.

disorder (called DOPA-responsive dystonia).

If you are a healthy adult, then you are making your own DOPA, all the time. The levels attained in the bloodstream, however, are about one-thousandth of those associated with PD treatment.

Cat-a-COLA-means

The next station on the catecholamine assembly line is the conversion of DOPA (which is a catechol but not a catecholamine), to dopamine, the grandfather in the catecholamine family. This step takes place in

many types of cells, not just cells with the rest of the machinery required to store, release, and recycle catecholamines.

To make dopamine from DOPA requires the enzyme, L-aromatic amino-acid decarboxylase (LAAAD, sometimes called DOPA decarboxylase, or DDC), and the cofactor pyridoxal phosphate, which is vitamin B6. (Incidentally, the word “vitamin” comes from “vital amine,” even though several vitamins, including B6, are not amines at all.)

Because DOPA is a neutral amino acid, it is taken up from the bloodstream by all types of cells in the body, and because many cell types, such as kidney and liver cells, contain LAAAD, in several organs dopamine is made from the DOPA after uptake of the DOPA from the bloodstream. The same holds true in cells of the brain. This may help explain how a patient with Parkinson disease, who has a severe loss of cells that store and release dopamine as a chemical messenger, can still have some benefit from taking levodopa.

The conversion of DOPA to dopamine involves cleaving off carbon dioxide from the molecule of DOPA. If you were to carry out this chemical reaction in a glass of water, the carbon dioxide gas would bubble up to the surface, like the effervescence in seltzer. Maybe this will help you remember that by this reaction, DOPA turns into a cat-a-

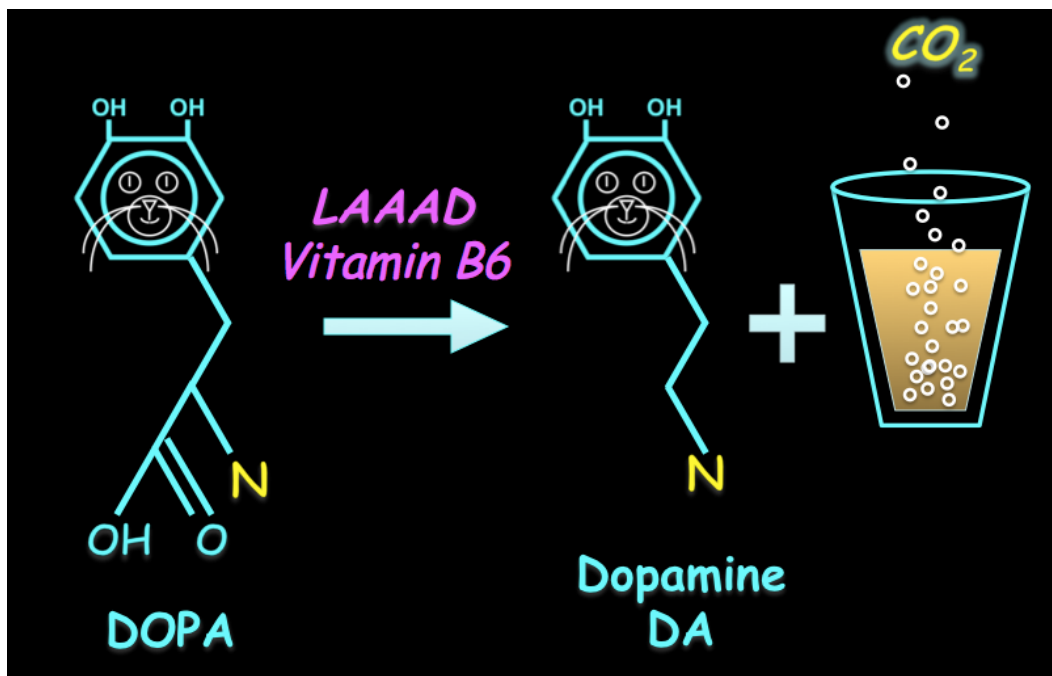

Conversion of DOPA to dopamine generates carbon dioxide, the bubbles in soda pop.

COLA-mean. (Actually, because of the rapid oxidation of dopamine in solution to form a tan breakdown product, you might better think about ginger ale.)

Without Vomiting

A drug called carbidopa is a catechol that blocks LAAAD. Carbidopa does not cross the blood-brain barrier. This means that if a patient were to take DOPA with carbidopa, the DOPA would not be converted

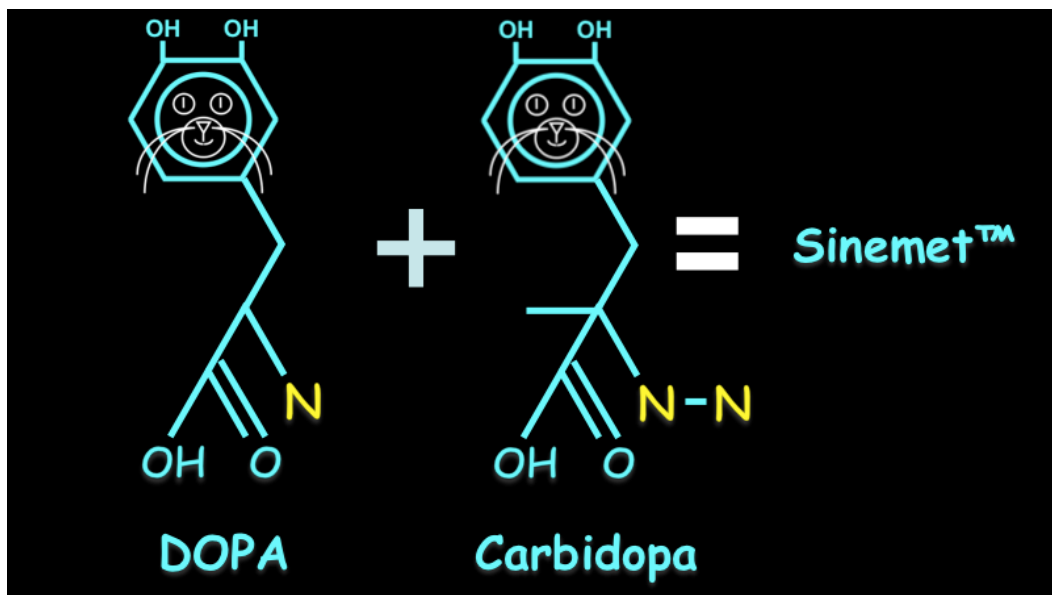

DOPA combined with carbidopa is Sinemet™, from the words for “without vomiting.”

as efficiently to dopamine by LAAAD outside the brain, whereas DOPA that entered the brain could be turned into dopamine by LAAAD in brain cells.

The combination of DOPA with carbidopa improves the efficiency of levodopa treatment for Parkinson disease, while decreasing the toxic effects from too much dopamine being made outside the brain.

The main such toxic effect of DOPA is vomiting, because of production of dopamine from DOPA in the vomiting center, which lies outside the blood-brain barrier in the brainstem. Giving carbidopa

with DOPA decreases the amount of dopamine production from DOPA outside the brain and therefore helps prevent DOPA-induced vomiting. This explains the brand name for the levodopa-carbidopa combination to treat Parkinson disease, Sinemet, from the Latin words for “without vomiting.”

Theoretically, carbidopa could prevent the production of all the catecholamines; however, it isn't very efficient, and in patients on Sinemet plasma levels of dopamine and its metabolites are actually increased.

The Weakest Link

The next step in making norepinephrine is the most complex, because it requires not only a specific enzyme and cofactors but also physical sequestration of dopamine into vesicles. It is only within the vesicles that norepinephrine—the main chemical messenger of the sympathetic noradrenergic system and a major neurotransmitter in the brain—is made. This is unlike acetylcholine and dopamine, which are produced in the cytoplasm.

Dopamine-beta-hydroxylase (DBH), which is the enzyme that converts dopamine to norepinephrine, is localized to the vesicles within noradrenergic neurons. This means that in order to produce norepinephrine, dopamine, which is synthesized in the cytoplasm,

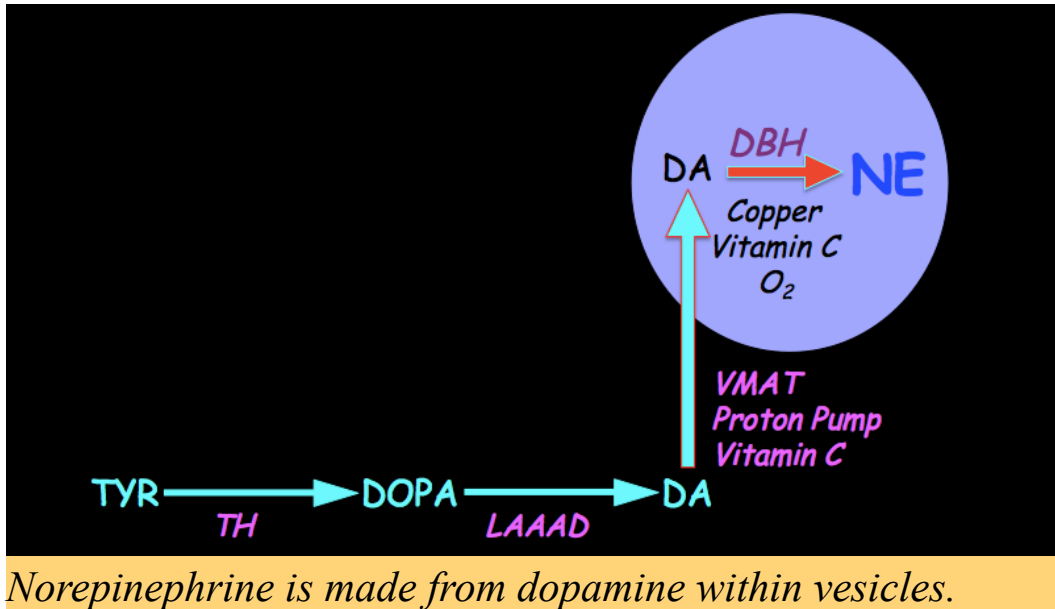

must be taken up into the vesicles.

In sympathetic noradrenergic nerves and in the brain, uptake into the vesicles is mediated by a transporter called the type 2 vesicular monoamine transporters (VMAT2). The uptake is an energy requiring process, meaning that it requires adenosine triphosphate (ATP). The energy is used to pump protons into the vesicles by a proton pump. This makes the inside of the vesicles acidic. As the protons leak out of the vesicle, dopamine comes in via the VMAT.

DBH is a copper enzyme. In order to convert dopamine to

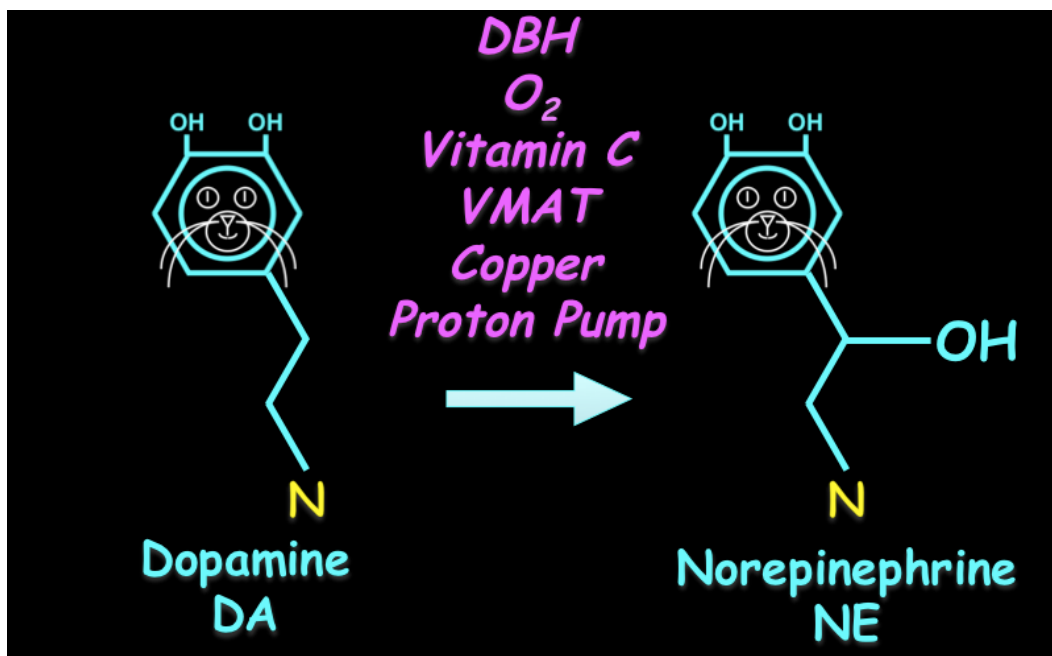

Several factors and processes are required in order to make norepinephrine from dopamine in the body.

norepinephrine, DBH must be supplied with copper. In a pediatric disease called Menkes disease, there is a mutation of the gene encoding a form of copper ATPase. Patients with Menkes disease do not synthesize norepinephrine normally, because copper doesn't meet up with DBH.

A variety of proton pump inhibitors (PPIs) are available by prescription or over the counter. Theoretically, they could interfere with vesicular uptake and thereby with norepinephrine synthesis. I once had a patient in whom this may have been the case. He had

physiological, neurochemical, and neuroimaging abnormalities consistent with decreased vesicular uptake and decreased norepinephrine synthesis, and I diagnosed him with probable pure autonomic failure. He was on a prescription PPI for severe gastroesophageal reflux. When I saw him in follow-up a couple of years later, all these abnormalities had disappeared, as if by magic. He reported that in the interim he had undergone successful surgery for his gastroesophageal reflux, and he no longer was on the PPI.

Since ascorbic acid (vitamin C) is a co-factor for DBH, it is theoretically possible that patients with scurvy have decreased norepinephrine synthesis. In normal volunteers deprived of vitamin C to the point of have symptoms and signs of scurvy, however, there is no evidence of a problem with norepinephrine production.

A Better World Through Recycling

Several types of nerve cells recycle their chemical messengers. Sympathetic nerves possess an ingenious processing mechanism that simultaneously inactivates the released chemical messenger norepinephrine, recycles the norepinephrine, limits its actions spatially to a small volume, and modulates the amount of delivery of the message to the target cells for a given rate of release. The processing mechanism is reuptake of the neurotransmitter from the

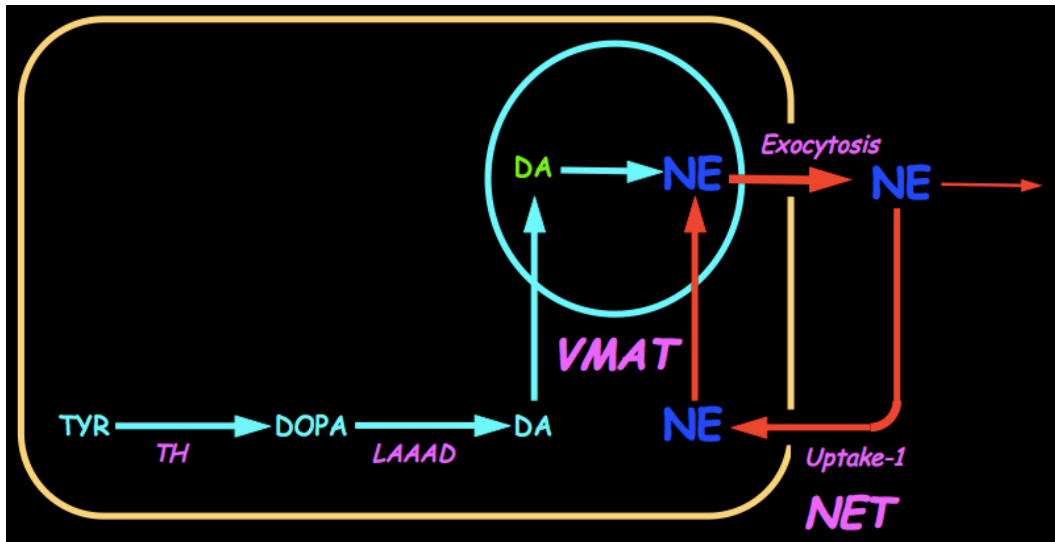

Norepinephrine recycling depends on the cell membrane norepinephrine transporter (NET) and the vesicular monoamine transporter (VMAT).

fluid outside the cells (extracellular fluid). For discovering the role of reuptake, rather than simple metabolic breakdown by an enzyme, in inactivation of neurotransmitters, Julius Axelrod shared the Nobel Prize for Physiology or Medicine in 1970. He carried out this work at the NIH in the same Building 10 where I sit.

The reuptake process by nerves is relatively specific for the particular neurotransmitter. One might even define the type of nerve cell by the neurotransmitter it takes up. For the catecholamines, norepinephrine, adrenaline, and dopamine, reuptake takes place by a process originally called “uptake-1,” in contrast with “uptake-2” by cells other than

nerve cells. Now we know that uptake-1 involves at least two different transporters, which physically transport the neurotransmitter molecules into the cells.

The transporter for norepinephrine is called the cell membrane norepinephrine transporter, or NET. The transporter for dopamine is called the dopamine transporter, or DAT. One of the peculiarities of the functioning of these transporters is that although dopamine is more avidly taken up by the DAT than norepinephrine is, dopamine is also more avidly taken up by the NET than norepinephrine is.

We exploited this neurochemical quirk in developing a form of dopamine tagged with radioactivity to visualize sympathetic nerves in people by PET scanning, as you will read about later. The sympathetic nerves take up the radioactive dopamine via the NET.

The recycling process is completed by reuptake of catecholamines from the cytoplasm into storage vesicles by the VMAT. Because of the NET, the concentration of norepinephrine in the cytoplasm normally exceeds that in the fluid around noradrenergic cells by manyfold, and because of the VMAT, the concentration of norepinephrine in the vesicles normally exceeds that in the cytoplasm also by manyfold. As a result of these processes acting in series, the concentration of norepinephrine in the storage vesicles normally is several thousand times the concentration in the extracellular fluid. Now that's recycling!

At least five types of perturbation interfere with catecholamine recycling. Every one exerts profound effects both inside and outside the brain. The first is cocaine, which is a classic inhibitor of uptake-1. The heart depends heavily on uptake-1 to inactivate norepinephrine released from local sympathetic nerves, and cocaine administration can evoke severe heart problems, such as heart failure and even sudden cardiac death in apparently healthy people. A notorious example was Len Bias, the University of Maryland basketball star who died of the cardiac toxic effects of cocaine.

The second is the class of drugs for depression called tricyclic antidepressants. Some tricyclics are desipramine, imipramine, nortriptyline, and amitriptyline (brand names Norpramin, Tofranil, Pamelor, and Mylan). Another antidepressant that is not a tricyclic but is thought to work at least partly by inhibiting the NET is venlafaxine (Effexor). In general, tricyclic antidepressants inhibit uptake-1 but also decrease sympathetic nervous system outflows from the brain. As a result, they do not produce nearly as great an increase in the delivery of norepinephrine to its receptors in the heart as cocaine does.

The third is a type of drug that blocks the VMAT. Reserpine is the classic example of this type of drug. By depleting the stored chemical messengers outside the brain, reserpine usually drops blood pressure, and by depleting messengers inside the brain, it can produce



Len Bias, a star basketball player at the University of Maryland, died of acute cocaine cardiotoxicity.

depressed mood (as illustrated in the story of the depressed dog discussed elsewhere). Tetrabenazine (Xenazine™), an FDA approved drug for Huntington's disease-related chorea that has been used for other hyperkinetic movement disorders, inhibits the type 2 VMAT, VMAT2. Whether in humans tetrabenazine decreases norepinephrine synthesis does not appear to have been studied.

The fourth is a genetic mutation of the NET. This has been described so far in only one family. Because of decreased ability to recycle norepinephrine, people with this mutation have excessive delivery of norepinephrine to its receptors in the heart in situations that activate sympathetic nervous system outflows. One of these situations is simply standing up, and so NET deficiency constitutes a rare cause of

postural tachycardia syndrome (POTS), in which an inability to tolerate prolonged standing (orthostatic intolerance) is coupled with an excessive heart rate response to standing (postural tachycardia). Among other findings in POTS with NET deficiency is a predisposition to panic, possibly associated with excessive delivery of norepinephrine to receptors in the brain.

The fifth is excessive “leakiness” of the storage vesicles. Normally, because of the enormous concentration of norepinephrine in storage vesicles, norepinephrine leaks passively out of the vesicles at a high rate into the cytoplasm. Correspondingly, however, by way of the efficient VMAT, the norepinephrine is taken back up into the vesicles. For the VMAT to function requires a concentration gradient for hydrogen ion between the cytoplasm and the inside of the vesicles, with the vesicle contents acidic. In any situation in which the cytoplasm becomes acidic, such as anoxia (lack of oxygen), there is an increased net leakage from the vesicles, which taken to an extreme can deplete sympathetic nerves of their neurotransmitter and thereby disable them. This may help explain why patients in shock can rather suddenly have a vicious cycle of fall in blood pressure, buildup of acid in the bloodstream, and loss of sympathetic cardiovascular tone, leading to worsening of the fall in blood pressure and death within minutes.

Stress Vitamins



Stress vitamins contain vitamins B6 and C.

Production of adrenaline and other catecholamines requires some vitamins and minerals. Dopamine in the body comes from DOPA. To make DOPA requires the mineral iron.

Production of dopamine from DOPA, and therefore production of all the catecholamines, depends on the availability of pyridoxal phosphate, which is vitamin B6.

The conversion of dopamine to norepinephrine in the body requires ascorbic acid, which is vitamin C, as well as the minerals, magnesium and copper.

“Stress formulas” vary in their contents of these minerals, but as near as I can tell, they all contain vitamins B6 and C.

Of Mice and Men and Wine and Cheese

Although catecholamines are recycled efficiently in sympathetic nerves, a small percent of norepinephrine and dopamine present in the cytoplasm of sympathetic nerves undergoes metabolic breakdown by a process that is sped up by the enzyme, monoamine oxidase (MAO). MAO is found in the outer membrane of the mitochondria, the cell’s energy factory.

In the brain, MAO plays key roles in mood. Drugs that inhibit MAO and that get into the brain are effective antidepressants. Conversely, genetic deficiency of MAO-A activity causes extraordinary hyperactivity and aggressiveness in mice and men. A Dutch family with this deficiency attained notoriety for antisocial behavior, murder, and violent rape.

I use the phrase “mice and men” because in both mice and people MAO deficiency produces severe aggressive behavioral disorders, but only in the males. The gene for MAO is present on the X chromosome. In boys with a mutation on their single X chromosome, the disease is expressed, but in girls with the same

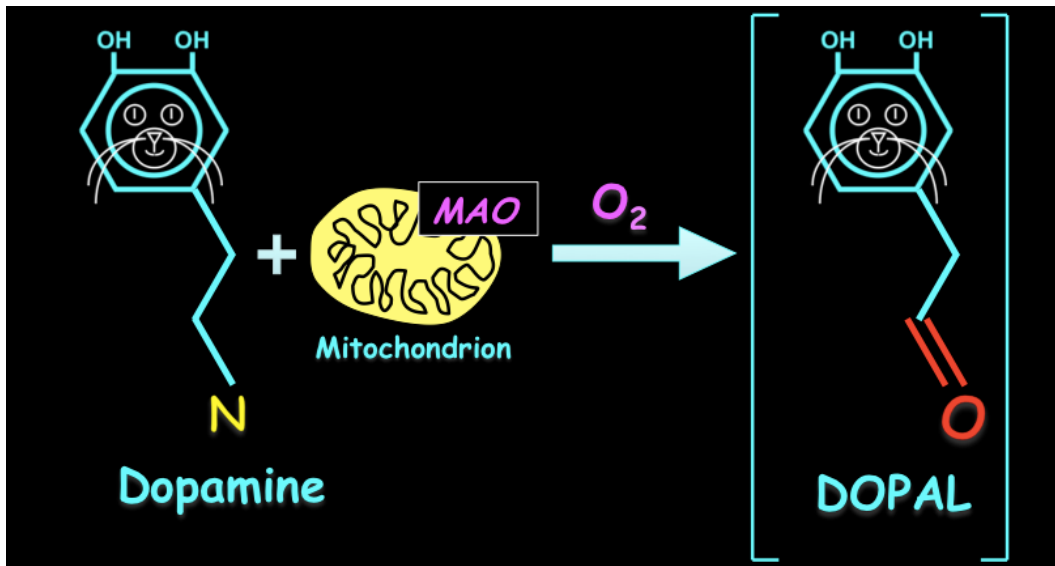

Dopamine is converted by MAO to the temporary metabolite, DOPAL.

mutation on one of their two X chromosomes, the disease is not expressed, and the girls are asymptomatic carriers. This means that in the family with “bad seed” from mutation of the MAO-A gene, none of the girls would have the disorder, but half of the at-risk boys would.

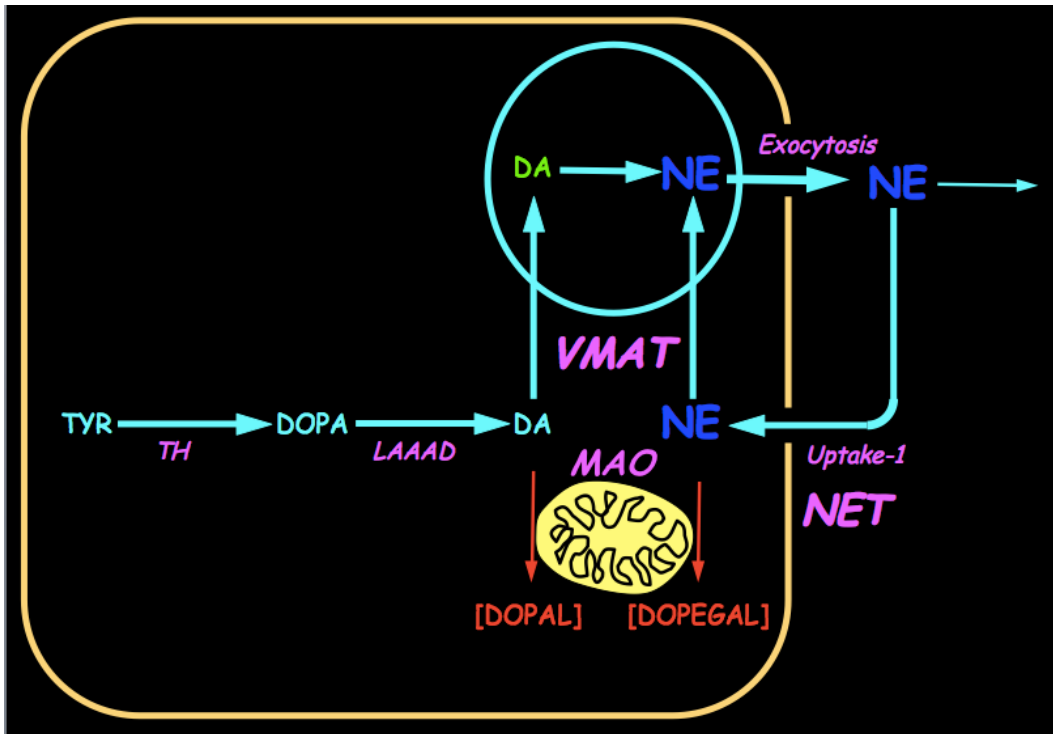

MAO acts on norepinephrine to form the intermediary metabolite DOPEGAL and on dopamine to form the intermediary metabolite DOPAL.

The Cheese Effect

No discussion of MAO would be complete without wine and cheese.

Red wine and hard cheeses contain abundant tyramine. Tyramine is an indirectly acting sympathomimetic amine. That is, it doesn't exert

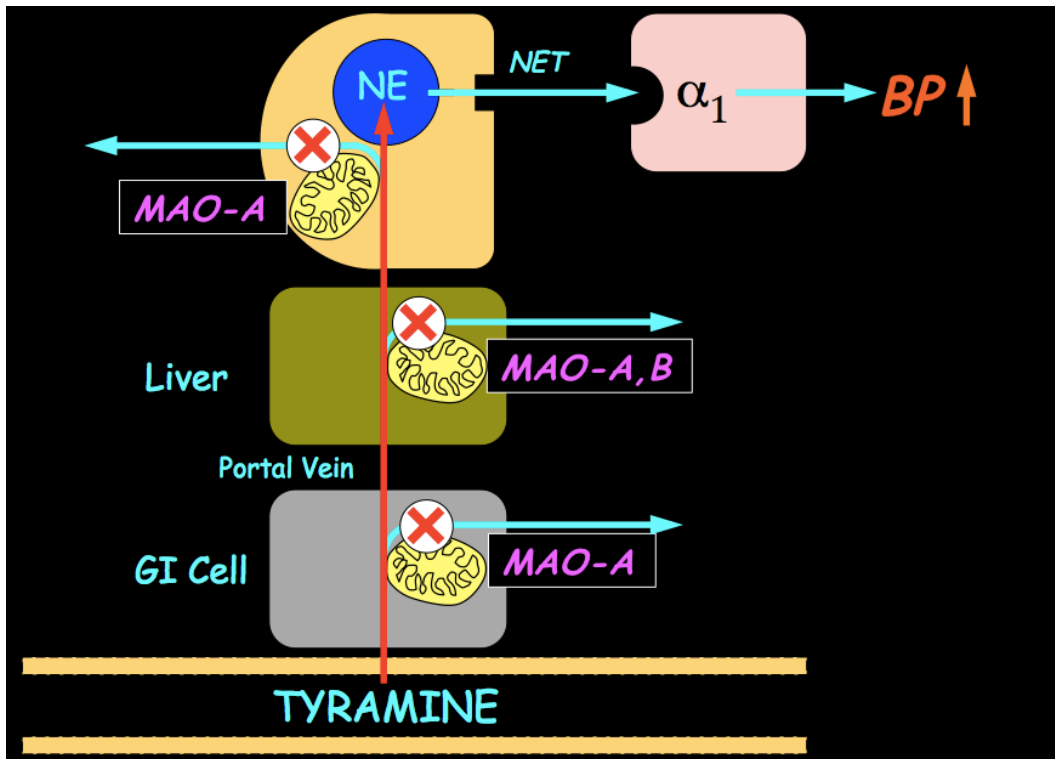

The “cheese effect.” If MAO is inhibited, tyramine in cheese can displace norepinephrine in sympathetic nerves, increasing blood pressure.

effects by itself, but it increases release of norepinephrine from sympathetic nerves. The released norepinephrine increases the blood pressure and the force of the heartbeat. Ordinarily, relatively little of ingested tyramine makes its way to the bloodstream because of an effective gut-blood barrier made up of a variety of enzymes, one of which is MAO. Patients taking an MAO inhibitor have a relatively permissive gut-blood barrier for substances that normally would be

broken down by MAO in the gut, one of which is tyramine. Sympathetic nerves take up tyramine by way of the cell membrane norepinephrine transporter, the NET. This means that the tyramine that has penetrated the gut-blood barrier can get into the sympathetic nerves. Once inside the nerves, tyramine in the cytoplasm gets taken up into the vesicles, by way of the vesicular monoamine transporter (VMAT), and once inside the vesicles, tyramine accelerates leakage of norepinephrine from the vesicles, possibly by alkalinizing them and decreasing the hydrogen ion gradient required for concentrating norepinephrine in the vesicles. Norepinephrine then builds up in the cytoplasm and can go backward through the NET to reach the fluid surrounding the cells or leave the vesicles that have fused with the membrane surface and have the “omega sign” opening to the extracellular fluid. By these mechanisms, norepinephrine is delivered to its receptors on cardiovascular cells, and the blood pressure and force of the heartbeat increase. In people taking an MAO inhibitor, such as for depression, ingestion of tyramine therefore can produce a paroxysmal increase in blood pressure or evoke an abnormal heart rhythm. If you were taking an MAO inhibitor for depression, you wouldn't want to attend a wine-and-cheese party.

There are two genes for MAO, which are near each other on the X chromosome, and there are two corresponding forms of MAO, called MAO-A and MAO-B. Sympathetic nerves express only MAO-A, whereas many other cell types express both forms. It is thought that the enzymatic gut-blood barrier for tyramine depends mainly on

MAO-A. Theoretically, the “cheese effect” would apply only to drugs that inhibit MAO-A or inhibit both forms of MAO. In particular, selegiline (also called l-deprenyl, brand name Eldepryl) and rasagiline (brand name Azilect), which are used to treat Parkinson disease, are relatively selective MAO-B inhibitors, and they are much less likely to cause a cheese effect than are drugs that inhibit MAO-A.

Dopamine Metabolism

DOPAL, the immediate product of MAO acting on dopamine, is an intermediate metabolite. It is rapidly and efficiently metabolized to a catechol acid, DOPAC. The enzyme responsible for this conversion is aldehyde dehydrogenase (ALDH).

Aldehydes like DOPAL are toxic, and yet they are made continuously in catecholamine neurons, because of the continuous appearance of the catecholamines in the cytoplasm. It is not surprising that in humans there are 19 different genes encoding forms of ALDH.

For ALDH to work requires a co-factor called NAD^+ . NAD^+ in turn is made in the mitochondria by an important process called complex 1. Drugs that inhibit complex 1 are toxic, and part of the toxicity may come from decreased availability of NAD^+ for ALDH to do its job in preventing buildup of aldehydes like DOPAL.

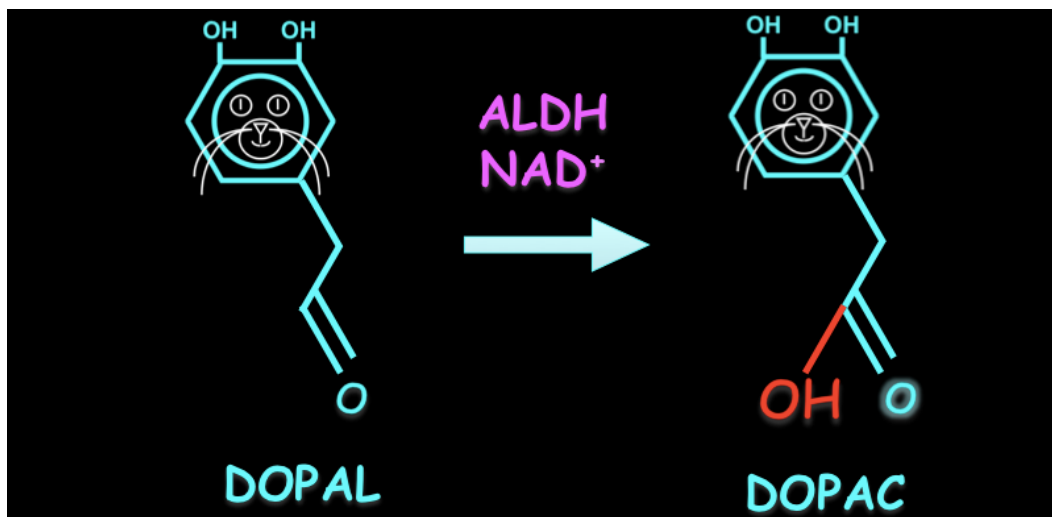

DOPAL is converted to DOPAC by the enzyme ALDH.

The product of ALDH acting on DOPAL is the catechol acid, DOPAC. DOPAC is actively extruded from the cell. Non-neuronal cells contain an enzyme called catechol-O-methyltransferase, or COMT. COMT transfers a methyl group to DOPAC, with S-adenosyl-methionine (SAME) serving as the methyl group donor, to form homovanillic acid (HVA).

HVA is the main end-product of dopamine metabolism in the body.

One of the surprising facts about dopamine metabolism in the body is that most of the synthesis and metabolism of dopamine takes place not

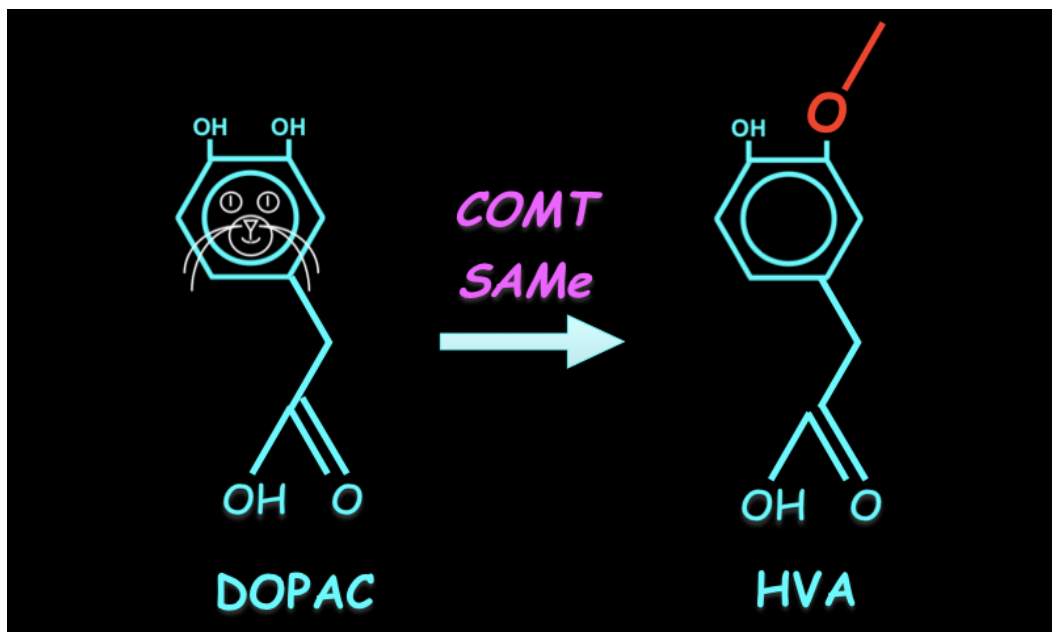

DOPAC is converted to HVA by the enzyme COMT.

in the brain or in the autonomic nervous system—not in nerves at all—but in non-neuronal cells in the gut.

A second surprising fact is that there is a very large amount of DOPAC in the urine—more than can be accounted for by filtration of DOPAC in the plasma reaching the kidneys. Most of the dopamine, and probably most of the DOPAC, in the urine comes from uptake and decarboxylation of circulating DOPA by non-neuronal cells in the kidneys.

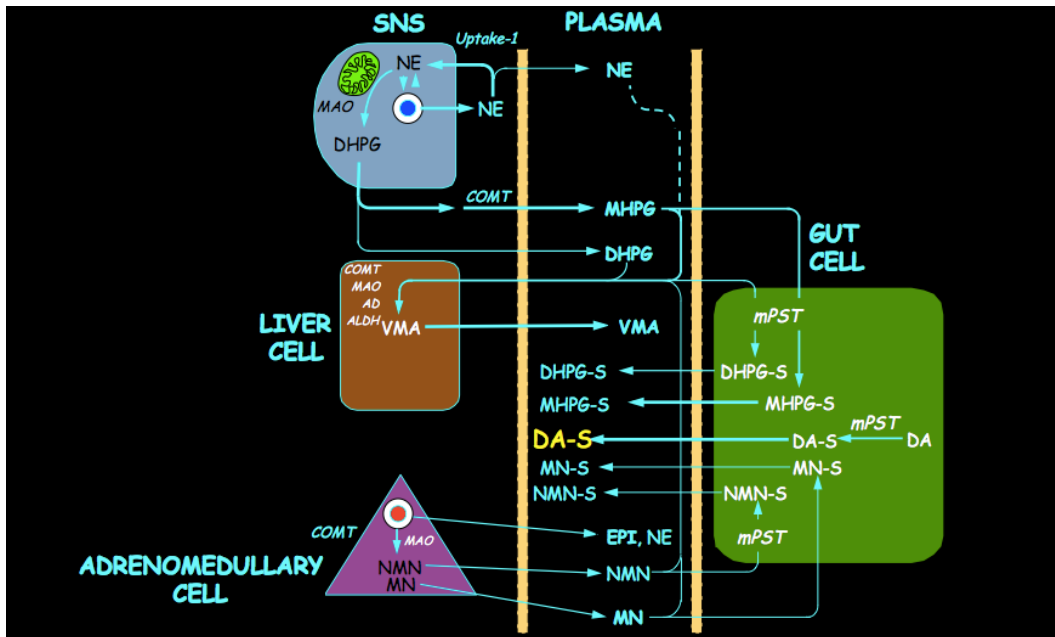

Most of circulating dopamine is in the form of dopamine sulfate.

A third surprising fact about dopamine metabolism is that virtually all of dopamine in the plasma is not in free form but is conjugated with sulfate and circulates as dopamine sulfate. The conjugation takes place in the gut via an enzyme called phenolsulfotransferase.

Dopamine neurons in the brain do not express DBH and therefore do not synthesize norepinephrine. The schema of metabolism of dopamine in such neurons is simpler than that in sympathetic nerves.

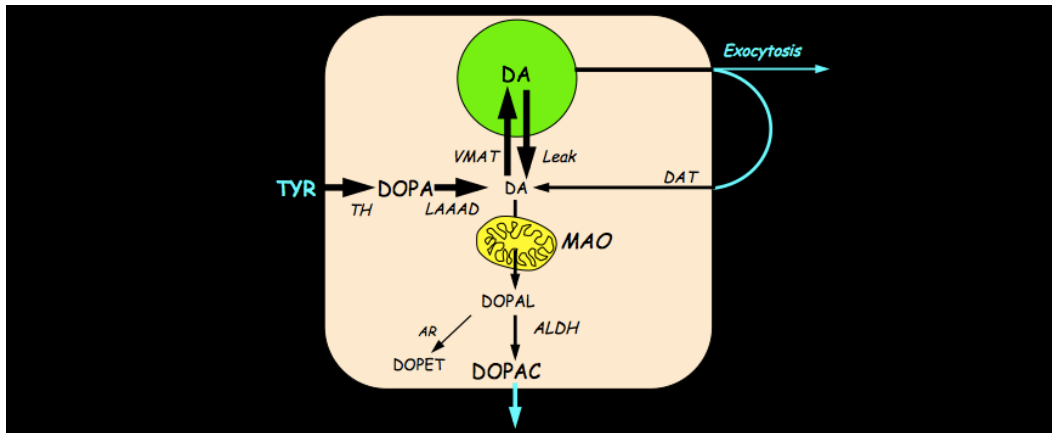

Dopamine metabolism in dopaminergic neurons

Norepinephrine Metabolism

In many ways metabolism of norepinephrine resembles that of dopamine, but there are a few differences.

3,4-Dihydroxyphenylacetaldehyde (DOPEGAL), the immediate product of MAO acting on norepinephrine, is an intermediate metabolite. Norepinephrine is a poorer substrate than dopamine is for MAO, and so the production of DOPEGAL from norepinephrine is slower than is the production of DOPAL from dopamine.

Whereas DOPAL is metabolized mainly to the acid, DOPAC, by ALDH, DOPEGAL is metabolized mainly to the glycol, 3,4-

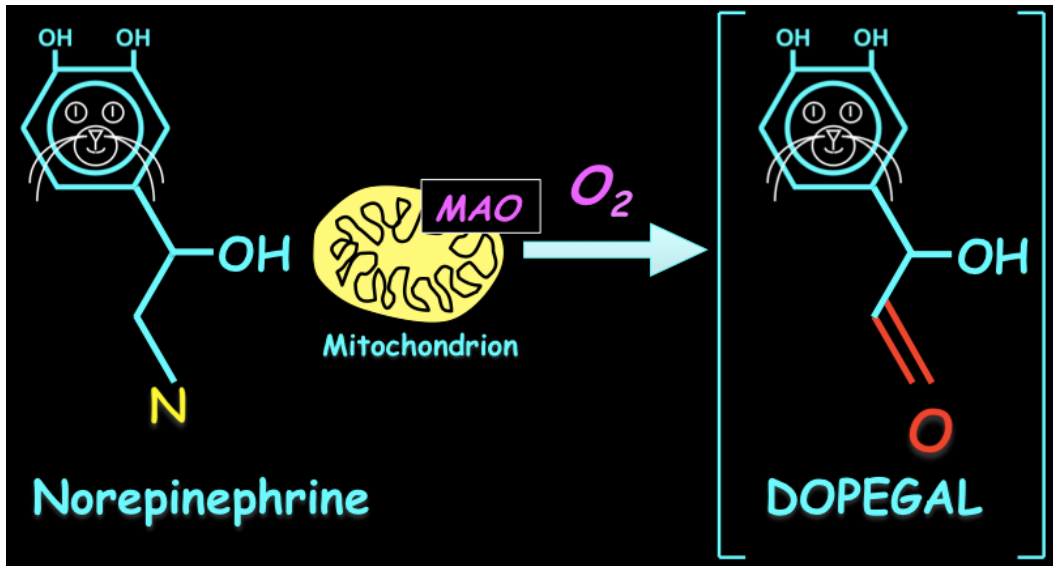

Norepinephrine is converted to the intermediary metabolite, DOPEGAL, by MAO.

dihydroxyphenylglycol (DHPG), by aldehyde/aldose reductase (AR).

As a glycol, DHPG crosses cell membranes readily. In non-neuronal cells, which contain COMT, DHPG is methylated to form 3-methoxy-4-hydroxyphenylglycol (MHPG), again with SAmE serving as the methyl group donor. In the liver, MHPG is converted to vanillylmandelic acid (VMA) by alcohol dehydrogenase and ALDH.

Both MHPG and VMA are major end-products of norepinephrine metabolism.

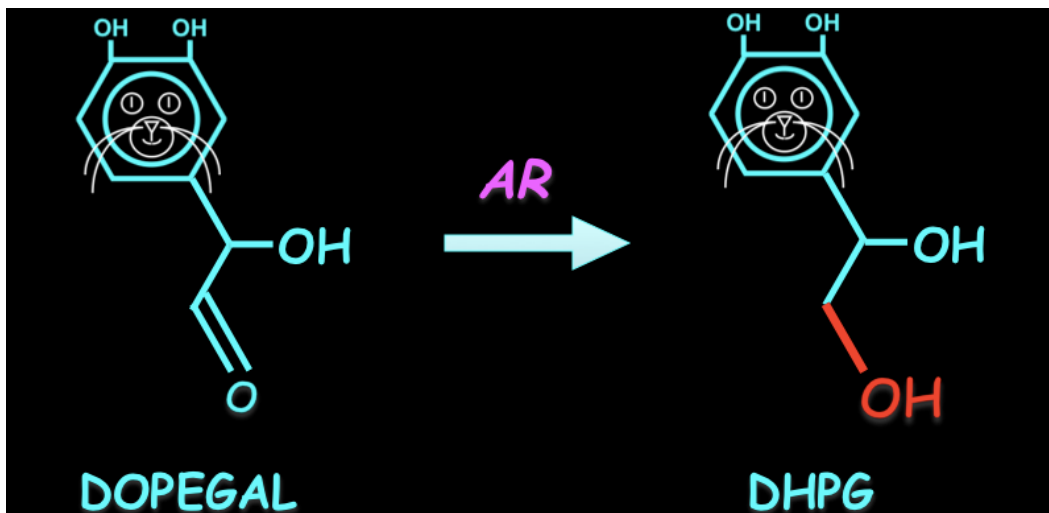

DOPEGAL is converted to DHPG by aldehyde/aldose reductase.

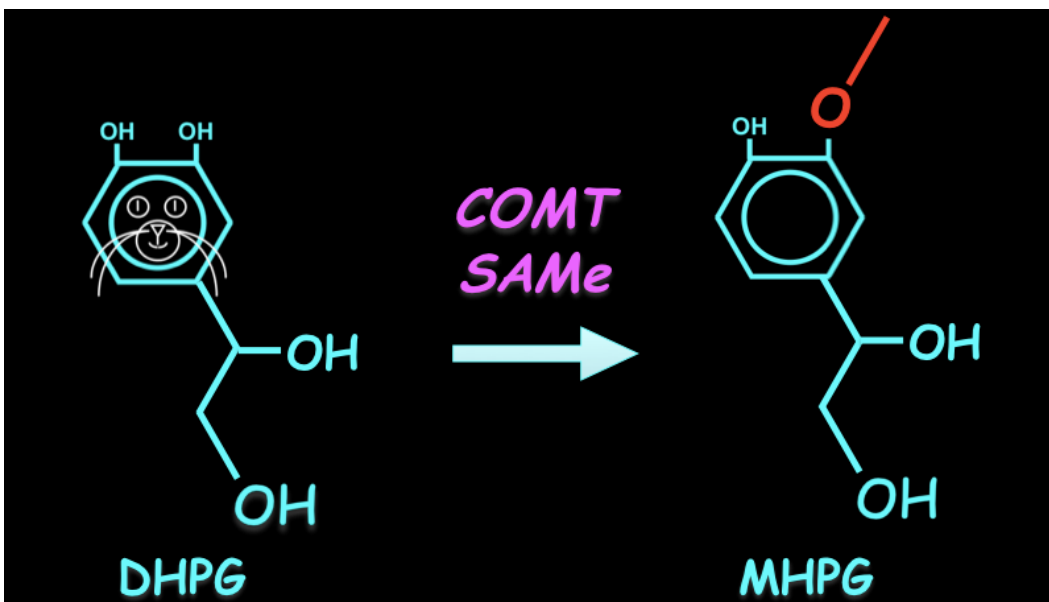

DHPG is converted to MHPG by COMT.

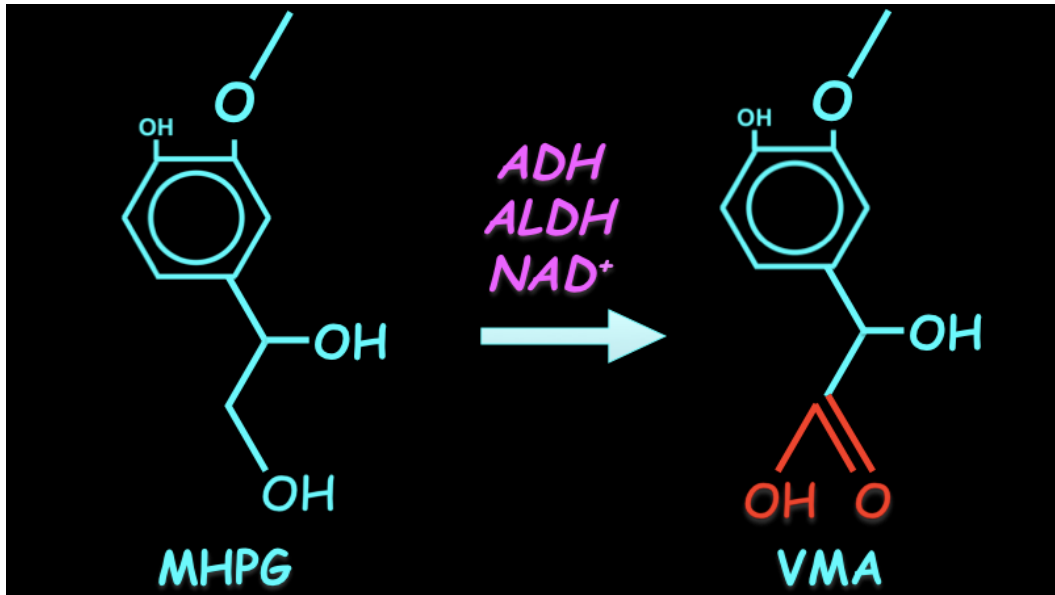

In the liver, MHPG is converted to VMA.

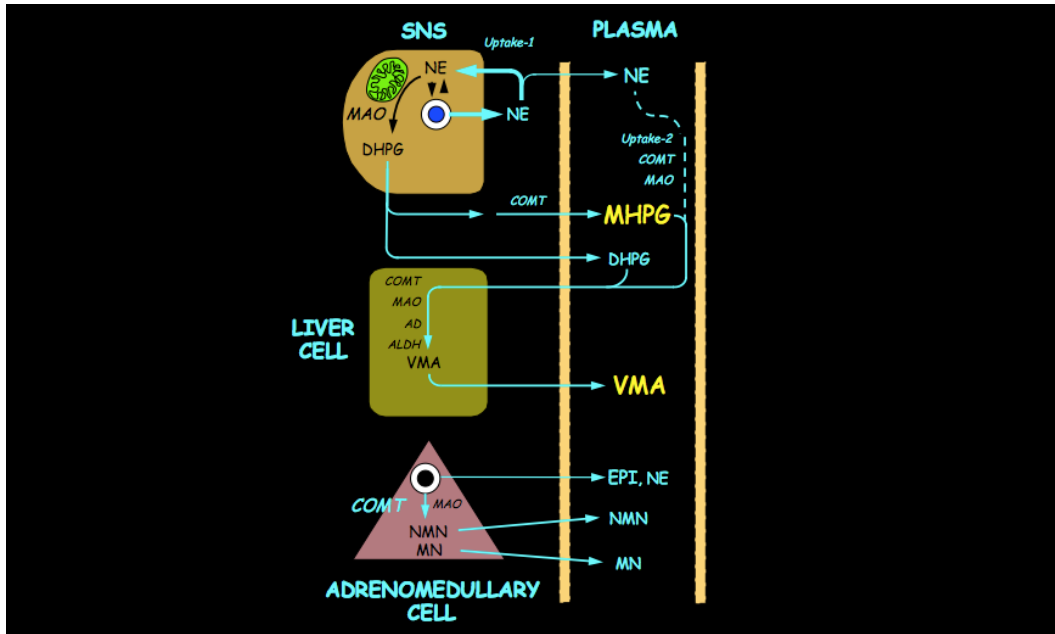

MHPG and VMA are the main end-products of norepinephrine metabolism.

The Adrenal Medulla

The synthesis of adrenaline (epinephrine, EPI) by cells of the adrenal medulla is rather complicated, and the metabolism of catecholamines in adrenomedullary cells is different from the metabolism of catecholamines in sympathetic nerves or in catecholamine neurons in the central nervous system.

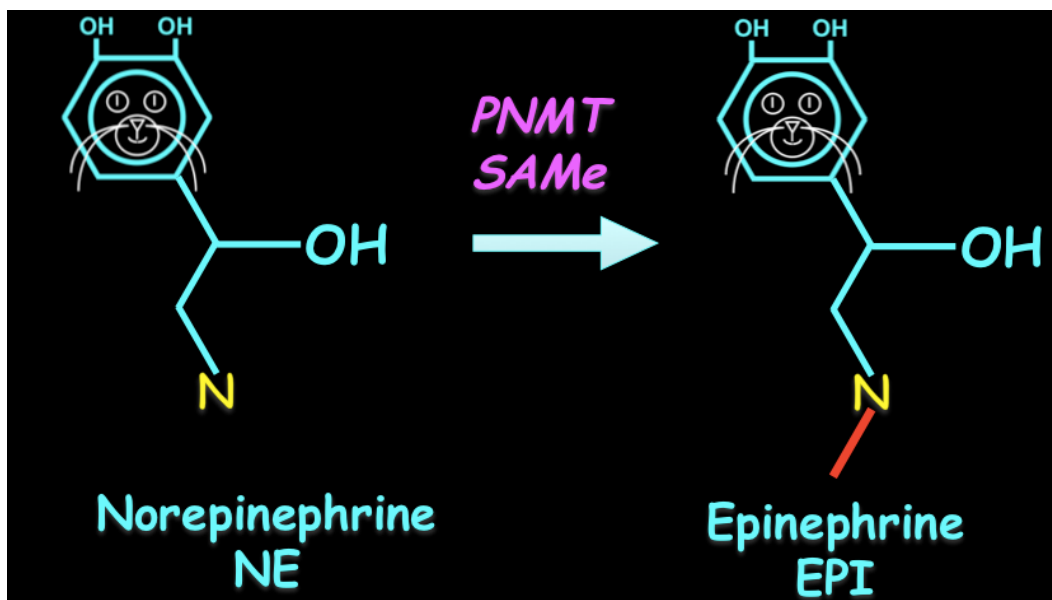

Norepinephrine is converted to epinephrine via phenylethanolamine-N-methyltransferase (PNMT), with SAMe as the methyl group donor.

Epinephrine is made in the cytoplasm, by the action of phenylethanolamine-N-methyltransferase (PNMT) on norepinephrine. S-adenosyl methionine (SAMe) is the methyl group donor. This doesn't necessarily mean that EPI is made from norepinephrine that has leaked from the vesicles into the cytoplasm. The adrenal medulla contains NE-producing and EPI-producing cell populations. Only the EPI-producing cells express the NET. This raises the possibility

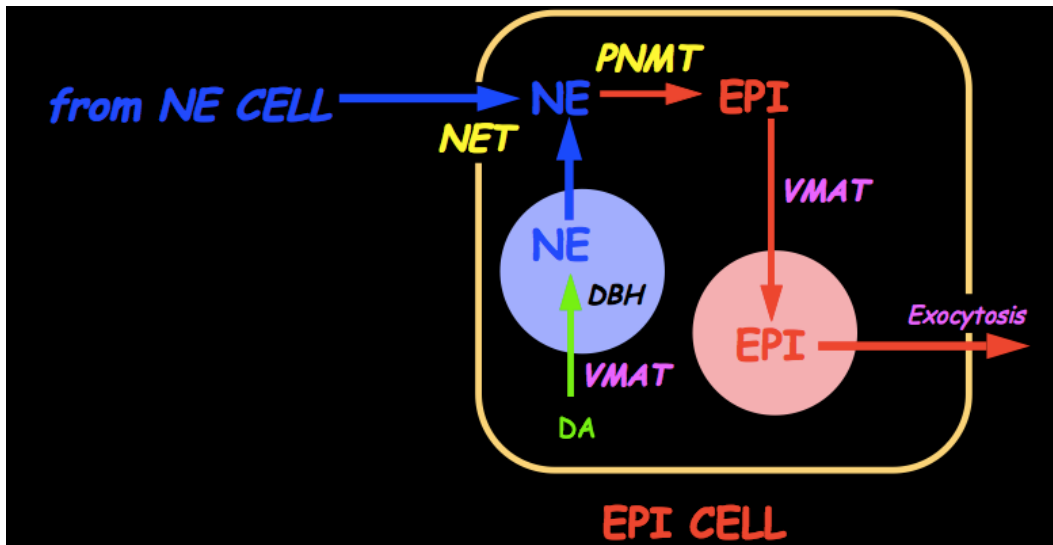

The adrenal medulla contains both NE and EPI cells. The EPI cells express PNMT and the NET.

that EPI can be made in the cytoplasm from NE taken up into the cells via the NET.

Adrenomedullary cells express catechol-O-methyltransferase (COMT), whereas sympathetic nerves and catecholamine neurons in the central nervous system do not. As a result, adrenaline in the cytoplasm of adrenomedullary cells can be converted to metanephrine, and norepinephrine can be converted to normetanephrine. Because of the ongoing leakage of catecholamines from the vesicles into the cytoplasm, in the adrenomedullary cells metanephrine and normetanephrine are made all the time, even in the

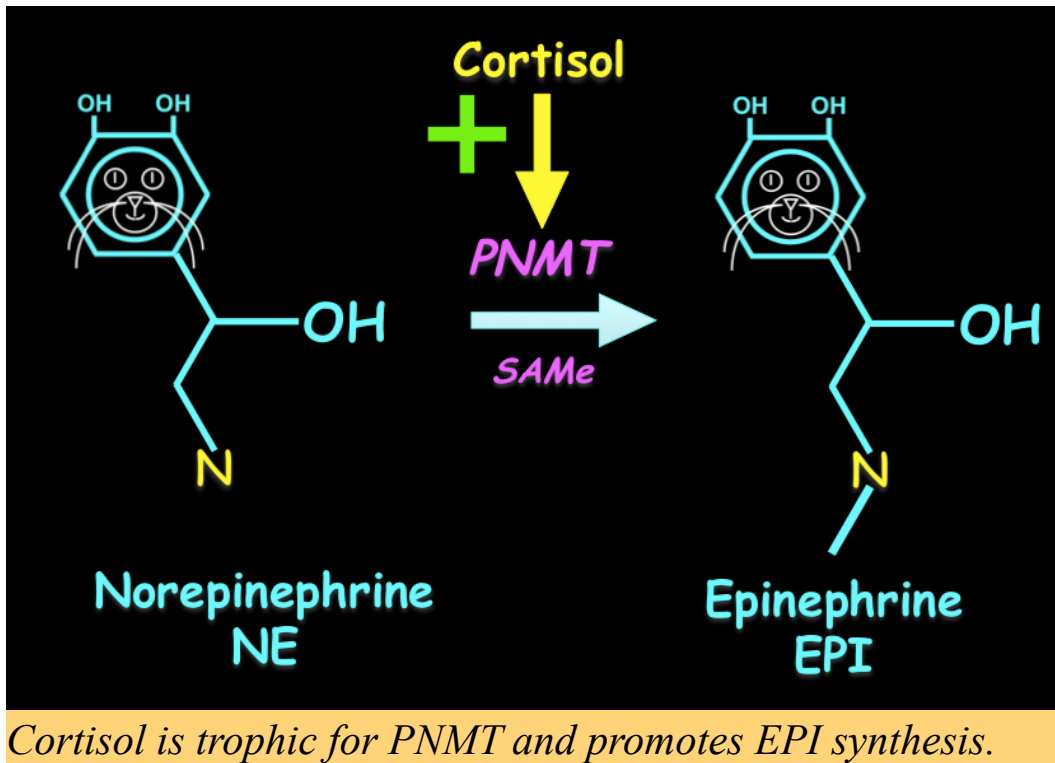

absence of catecholamine release. This explains why plasma levels of metanephrines (unconjugated normetanephrine and metanephrine) are sensitive indices of pheochromocytoma.

Blood flow in the adrenal gland goes from the cortex through the medulla. As a result, adrenomedullary cells are bathed in high concentrations of adrenocortical steroids. Cortisol, the main glucocorticoid in the human adrenal cortex, is trophic for PNMT. In addition, the adrenal medulla contains abundant receptors for angiotensin II, and angiotensin II evokes secretion of catecholamines.

Adrenomedullary function therefore seem to be more susceptible than sympathoneural function to hormonal influences.

Summary of Catecholamine Synthesis & Metabolism

Here is a summary diagram of norepinephrine synthesis and metabolism. There are a few general principles to keep in mind.

First, dopamine and norepinephrine have a single source, DOPA.

Second, dopamine is made in the cytoplasm, whereas norepinephrine is made in the vesicles.

Third, released norepinephrine is recycled by uptake into the cytoplasm via the NET and uptake into the vesicles via the VMAT.

Fourth, in healthy people, the main determinant of catecholamine turnover is not release by exocytosis followed by extra-neuronal metabolism but vesicular leakage followed by MAO.

Finally, as emphasized in this overview, end-products of catecholamine metabolism are formed in the gut and liver.

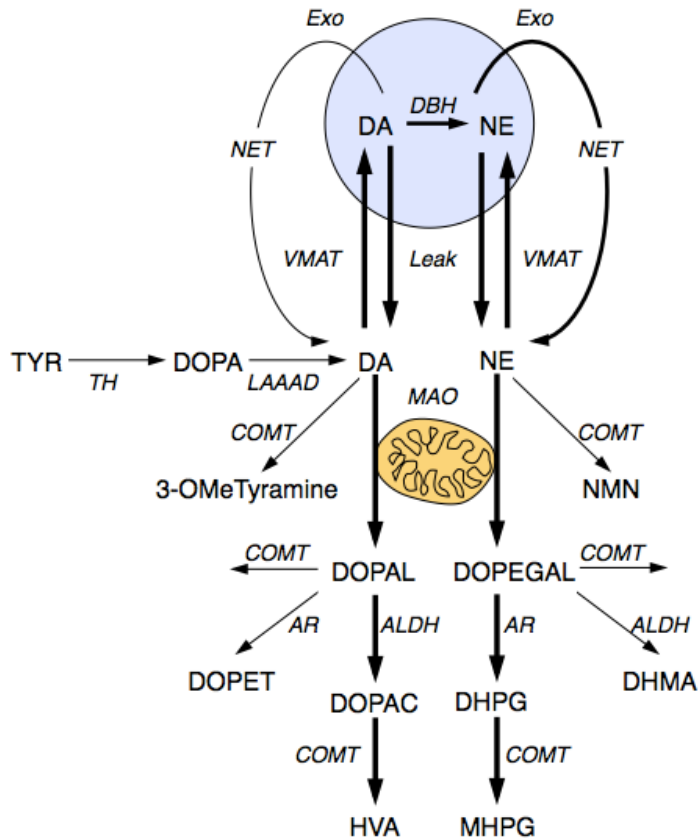

An overview of catecholamine synthesis and metabolism.

Catecholamines in the Brain

The concepts introduced by Carlsson about dopamine in the brain led

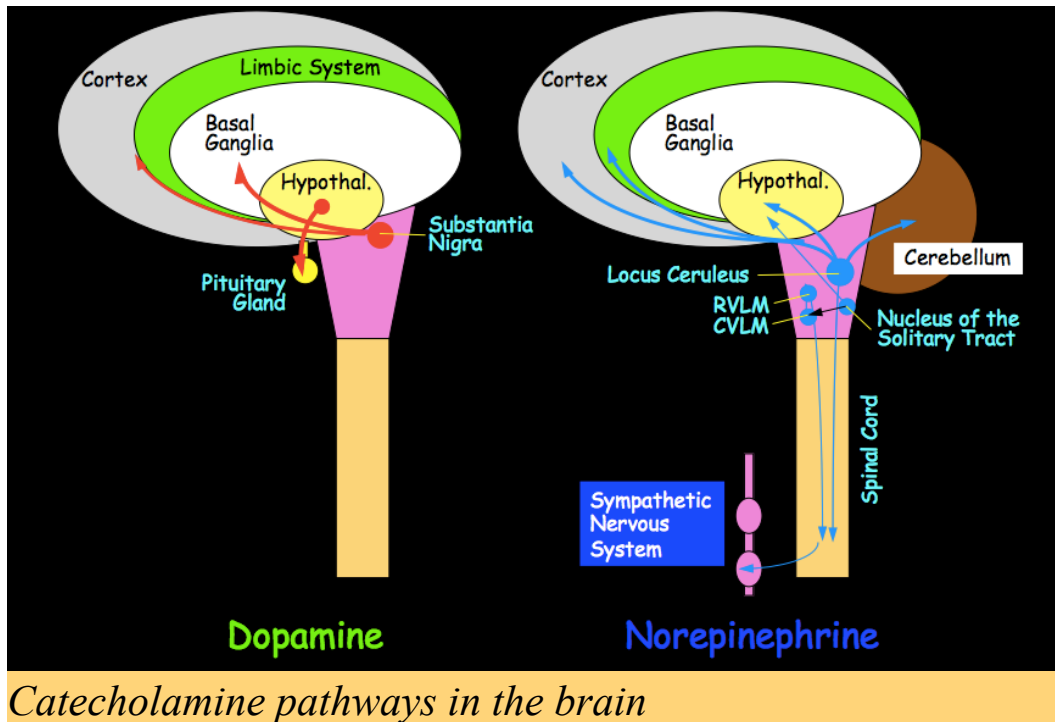

to an avalanche of research about catecholamines in psychiatry and neurology. A tremendous amount of attention has by now been paid to catecholamine systems in the brain.

Catecholamine in the brain are found in two norepinephrine and three dopamine pathways. Several different functions of dopamine have been proposed in its three chemical pathways.

The nigrostriatal system is the main source of dopamine in the brain and the main determinant of dopamine effects on movement. Patients with Parkinson disease experience particular difficulty with "pill-roll"

tremor at rest and with initiating and terminating movements, presumably because of nigrostriatal dopamine deficiency. The nigrostriatal system courses from a tiny cluster of pigmented cells in the substantia nigra (“black substance”) in the midbrain portion of the brainstem to much larger structures toward the middle front of the brain. These structures have collectively been called the “basal ganglia.” The nomenclature for the components of the basal ganglia is notoriously complex. The basal ganglia include the caudate (tail-like) nucleus and lenticular (“lens-like”) nucleus. The lenticular nucleus, in turn, consists of the putamen and globus pallidus. The corpus striatum, often simply called the striatum, consists of the caudate and putamen. One would think the striatum and basal ganglia would be synonymous, but some authorities include other components in the basal ganglia.

The mesolimbic (or mesocortical, or mesolimbocortical) system sends dopamine fibers from the substantia nigra to parts of the limbic system, such as the amygdala, and several associated structures, such as the anterior cingulate cortex, septal nuclei, and nucleus accumbens. It is thought that this system is dysfunctional in schizophrenia, because many effective drugs for schizophrenia appear to work by blocking the effects of dopamine released in this system. In the mesolimbic system, dopamine seems to increase locomotion and positive reinforcement, not so much due to pleasurable reward sensations as due to an enabling action that decreases the threshold for initiating responses.

Finally, the tuberoinfundibular (or tuberohypophyseal) system delivers dopamine from cells in the hypothalamus to the pituitary gland. Dopamine in the pituitary gland inhibits production of prolactin. In postpartum women who don't want to breast-feed, a single injection of bromocriptine, which stimulates dopamine receptors, prevents lactation.

Complete destruction of all dopamine systems in the brain produces a syndrome of decreased movement, inattention, decreased food intake, and decreased fluid intake; it gives the appearance of generalized behavioral unresponsiveness. This “dopamine deficiency syndrome” applies to all voluntary acts requiring motivation, sustained alertness, and receptiveness to sensory input. Animals deficient in dopamine fail to initiate coordinated movements and fail to orient to sensory stimuli. Motivated behaviors are not eliminated, but the arousal threshold appears to be an increased before the behaviors are elicited. Most of the research in this area has depended on administration of a neurotoxin to produce chemical destruction of dopamine cells and terminals; however, the same neurotoxin also destroys norepinephrine cells and terminals, and researchers have paid surprisingly little attention to the interactions between norepinephrine and dopamine systems in the brain.

Conversely, increased occupation of dopamine receptors in the brain, such as produced by DOPA, amphetamines, or drugs that stimulate dopamine receptors directly, produces hyperactivity, stereotyped

involuntary movements, agitation, psychosis, and risk taking. Patients with Parkinson disease who take dopamine receptor stimulants can have a surprisingly high frequency of an unusual side effect—gambling.

Norepinephrine also is an established neurotransmitter in the brain, but very little is known about what it does in humans. Based on studies in animals, norepinephrine, rather than acting as a direct inhibitor or stimulator of neuronal function, seems mainly to modify responsiveness to other inputs. Activation of the locus ceruleus, the brainstem source of most of the norepinephrine in the brain, biases attention toward novel, rapidly changing signals from sense organs monitoring both the outside and inner worlds. Norepinephrine in the locus ceruleus system may therefore play a role in vigilance behavior and in registration of distressing events into long-term memory.

A pathway from norepinephrine-producing cells of the locus ceruleus down the spinal cord seems to contribute to “stress-induced analgesia.”

Lower in the brainstem, norepinephrine-producing cells participate in neurocirculatory reflexes. Most of the evidence for such a role has come from studies of the baroreflex in laboratory animals. For instance, norepinephrine-producing cells exist at high concentration in the nucleus of the solitary tract (NTS). The NTS is the main site of termination of input from the baroreceptors to the brain. From the

NTS, nerve fibers branch widely as they ascend to higher levels of the central nervous system, such as the hypothalamus and amygdala. Conversely, as part of coordinated behavioral, emotional, and autonomic nervous system responses, descending pathway traffic in fibers from higher centers to the NTS can “reset the barostat” and redefine “normal” blood pressure. A loss of norepinephrine-producing cells in the NTS can help explain why some neurodegenerative diseases feature extreme swings of blood pressure.

Despite the fact that both dopamine and norepinephrine are established neurotransmitters in the brain, and despite the apparent involvement of dopamine systems and norepinephrine systems in determining responses to environmental and internal inputs, interactions between dopamine systems and norepinephrine systems have received remarkably little research attention, especially in humans, and no concepts have emerged to explain whether and how these two types of catecholamine system work together in health or disease.

The Case of the Depressed Dog

I was testing whether a particular chemical our group had developed at the NIH, an analog of dopamine tagged with radioactivity, could successfully visualize sympathetic nerves by a special type of nuclear medicine scan called a PET scan. To test this idea, I studied a dog that had received a drug called reserpine.

Reserpine exerts a highly specific effect in the body. It prevents uptake of a class of neurotransmitters called monoamines into storage vesicles. If my hypothesis were correct, then treatment with reserpine would prevent uptake of the radioactive dopamine into the vesicles and therefore prevent visualization of the sympathetic nerves. In designing this experiment I didn't take into account that reserpine rapidly gets into the brain.

After the testing, the dog was returned to its kennel. Later I received a phone call from a very concerned veterinarian. The dog was lying in a corner, listless, almost motionless. Its tail was tucked underneath it, and it wouldn't wag its tail when a caretaker approached. It was poorly responsive, it wouldn't eat, and its blood pressure was low. The veterinarian thought the dog was seriously ill, such as from septic shock.

Instead it had a form of acute depression and dysautonomia, both of which could be ascribed to reserpine. Blocking uptake into vesicles prevented storage of monoamines in the vesicles. Normally they leak out, but they get taken back up into the vesicles by the vesicular monoamine transporter.

Because of the inability to recycle the monoamines, the sympathetic nerves rapidly became depleted of norepinephrine. This was the basis for the low blood pressure in the poor dog. Indeed, the leaf of the plant from which reserpine was isolated, *Rauwolfia serpentina*, was

the first successful drug treatment for hypertension.

The same blockade of vesicular uptake in the dog's brain resulted in rapid depletion of the monoamines norepinephrine, dopamine, and serotonin. Depletion of dopamine causes decreased spontaneous movement, decreased oral intake, and possibly a tendency to depression. Depletion of norepinephrine probably decreases vigilance behavior and may also tend to depression. Depletion of serotonin probably also tends to depression. Depletion of all three chemicals in the brain likely produced the depressed affect in the dog.

RECEPTORS

The main chemical messengers of the autonomic nervous system are acetylcholine and the catecholamines norepinephrine and epinephrine. Acetylcholine and norepinephrine are neurotransmitters, whereas epinephrine is a hormone.

All these chemical messengers exert their effects on body functions by receptors, highly specialized molecules embedded in the membranes of the target cells such as heart muscle cells.

The synthesis of these chemical messengers seems relatively simple compared to the bewildering arrays of the receptors.

Most drugs used to treat dysautonomias work by their effects on receptors.

Mushrooms and Tobacco

There are two classes of receptors for acetylcholine—muscarinic and nicotinic. These names are derived from the drugs muscarine, made in certain types of mushrooms, and nicotine, made in tobacco plants.

Inspection of the chemical structures of muscarine and nicotine show

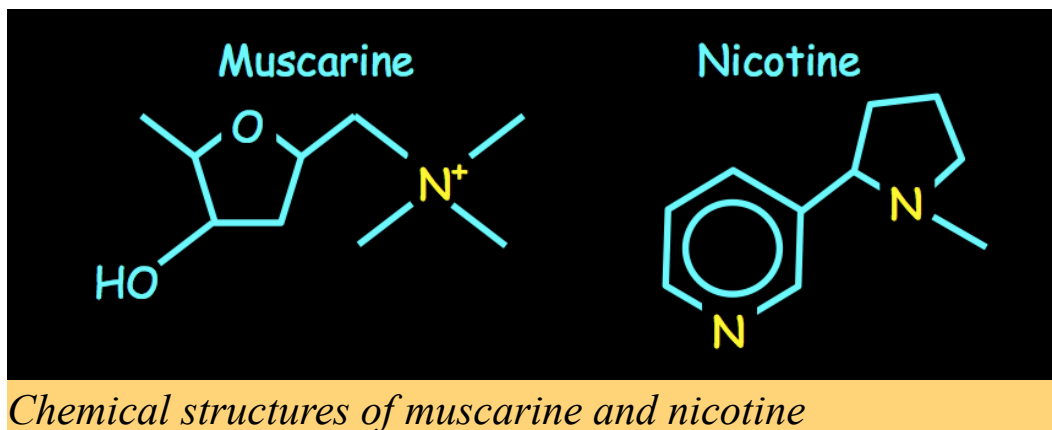

some similarities. They are both small molecules, and they contain prominent nitrogen atoms.

Muscarinic receptors are expressed in all the organs of the body, including the heart, gut, sweat glands, urinary bladder, and lungs. Probably the most noticeable effect of muscarinic receptor stimulation is gastrointestinal upset, with nausea and vomiting.

There are 5 different forms of muscarinic receptors. The M2 form is the main form in the heart. Stimulation of M2 receptors in the heart decreases the rate and force of heart contraction, via two processes. First, stimulation of M2 receptors on the heart muscle cells inhibits the cells' activities via decreasing generation of the second messenger cyclic AMP and increasing entry of potassium ion into the cells.

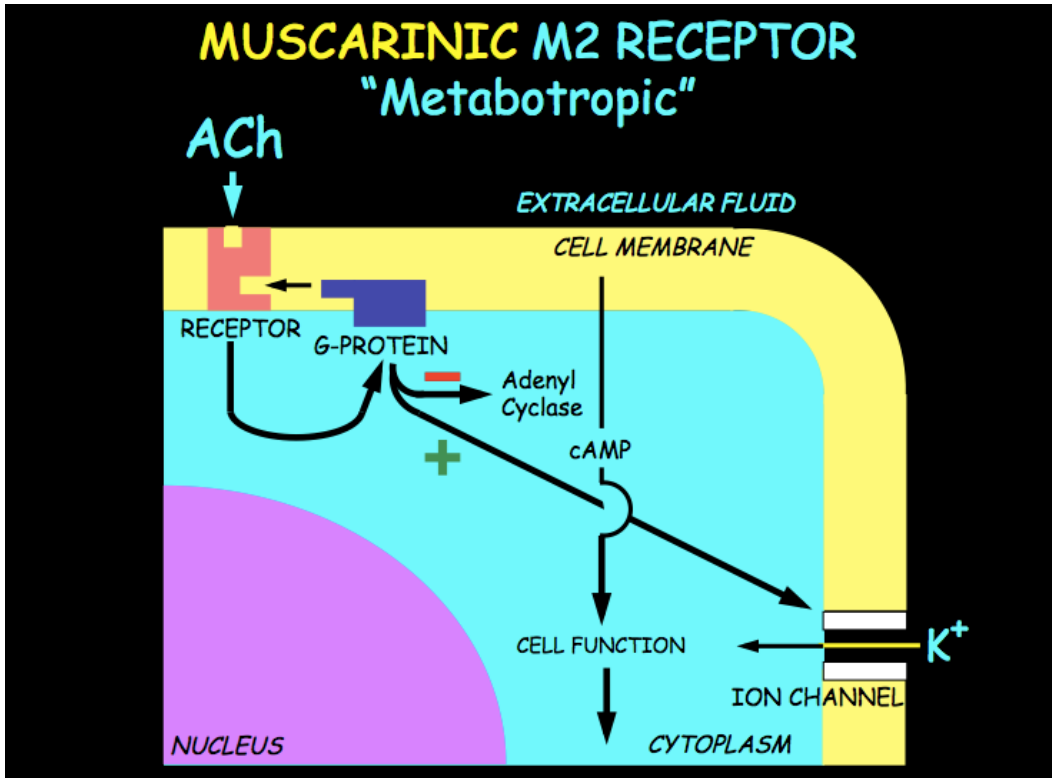

Muscarinic receptors are called "metabotropic," because they alter cell function via production of second messengers.

Second, stimulation of M2 receptors on sympathetic nerves inhibits norepinephrine release from the nerves.

Magic Mushrooms 101

When I was a junior resident in internal medicine in Seattle, I was working in the emergency room one night when a group of students



A chemical found in some mushrooms was the basis for naming one class of acetylcholine receptors—muscarinic.

came in, all looking acutely ill. They had ingested what they thought were psychedelic (psilocybin) mushrooms. It didn't take long before they realized they'd made a big mistake. All were retching and vomiting. In the vomitus were some mushroom parts.

At the time, on the faculty of the University of Washington was professor of botany who was a renowned authority on mushrooms. Daniel Stuntz was a recipient of the University's Distinguished Teaching Award. We called him up, and he came in. I remember him wearing a professorial cardigan sweater, which contrasted with our medical white jackets.

Dr. Stuntz truly was an expert on the subject. In 1972, he discovered a new species of the psychedelic mushroom *Psilocybe* on the UW campus. It was later named *Psilocybe stuntzii* in his honor.

He identified the matter in the students' vomitus as a variety of poisonous mushroom called *amanita phalloides*, also known as "death cap." The retching and vomiting were from muscarinic toxicity.

It's a Girl!

When my brother and sister-in-law had their youngest daughter, they gave me an It's a Girl! cigar. I never have been a tobacco smoker, but given the occasion I thought I should smoke it. My wife wouldn't let me smoke in the house, so I decided to take a leisurely stroll in the neighborhood around our long block. I lit up and started my walk, and as I puffed away I held my chin up high with my hands clasped behind my back. About half way through, though, I suddenly came to the realization that I was about to die.

My heart was racing, I broke out in a sweat, I gasped for breath, I began to tremble, and, most tellingly, I experienced what in medical circles is called the "feeling of impending doom." I made it home and flung myself on the couch in our family room. From my pallor, sweating, hyperventilation, and speech, everyone was immediately concerned and wanted to know what was wrong. I gasped, "It's that damned It's a Girl! cigar."

All my symptoms and signs were due to adrenaline, released by my adrenal glands upon occupation of nicotinic receptors on my adrenal medullary cells.

In non-smokers, the nicotine in tobacco smoke releases adrenaline, producing fast pulse rate, sweating, pallor, hyperventilation, and a “feeling of impending doom.”

The history of acetylcholine receptors begins with John Newport Langley, the same Langley who coined the terms “autonomic nervous system” and “parasympathetic nervous system.” In 1905 Langley proposed that skeletal muscle expresses “a substance that combines with nicotine and curare...receives the stimulus and transmits it.” He referred to a “receptive substance” in the muscle.

Nicotine is the classic stimulator of the neuronal nicotinic receptor, the first type of neurotransmitter receptor to be identified.

There are numerous types and sub-types of nicotinic receptors. All have 5 component parts—i.e., they are pentamers. For instance, a common arrangement in the sympathetic ganglia is a pentamer that has 2 alpha-3 subunits and 3 beta-4 subunits.

Nicotinic receptors are called “ionotropic,” because when occupied by

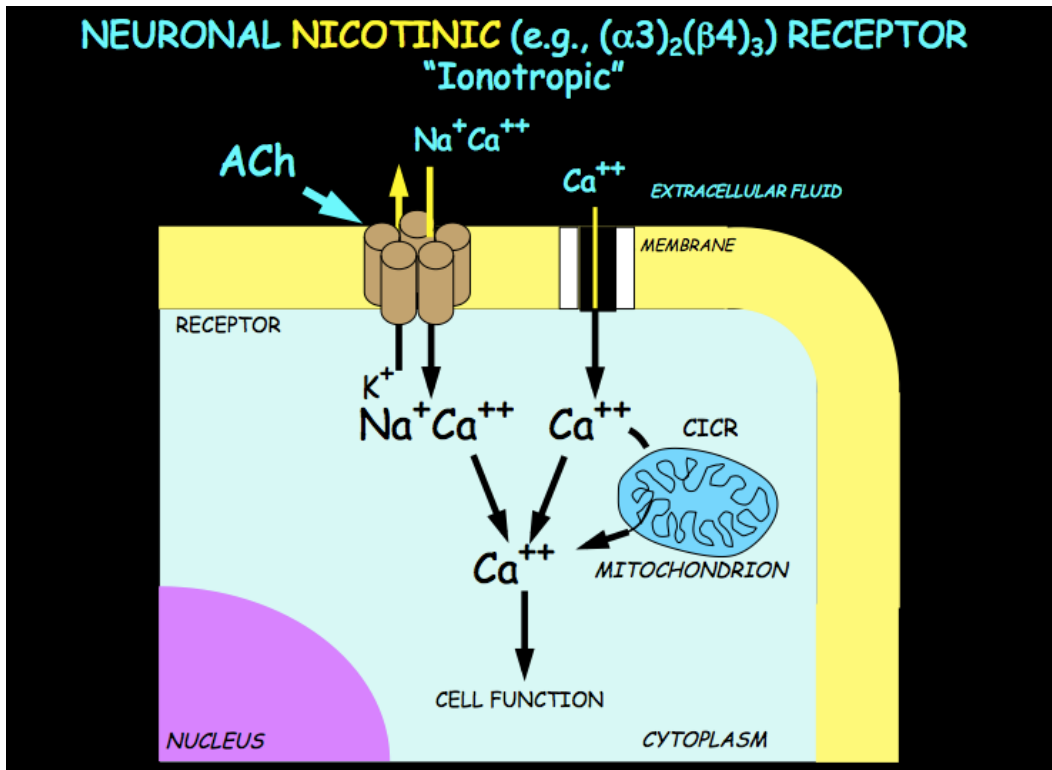

Nicotonic receptors are ionotropic, because they stimulate the cell by building up ions in the cytoplasm.

acetylcholine they let in ions from the extracellular fluid. By letting in sodium ions the cell loses some of its charge (depolarizes), and the depolarization lets in calcium ion. Calcium ion also can get into the cell through the receptor itself, or it can induce calcium release from intracellular organelles such as the endoplasmic reticulum or mitochondria. It is the buildup of ionized calcium that activates the cell. In adrenal medullary cells, exposure to nicotine rapidly evokes release of catecholamines.

"First I Secreted a Hell of a Lot of Adrenaline"

About the same time that US von Euler identified norepinephrine as the neurotransmitter of the sympathetic nervous system (disproving Cannon's notions about adrenaline being the sympathetic neurotransmitter), Raymond P. Ahlquist proposed an explanation for the impressively large variety of effects of the two rather simple chemicals.

Ahlquist's idea was that catecholamines differentially stimulate specific receptors—adrenergic receptors or adrenoceptors. In 1948, he suggested that there were two types of adrenoceptors, alpha and beta. Norepinephrine would stimulate alpha adrenoceptors, the synthetic catecholamine, isoproterenol, would stimulate beta adrenoceptors, and adrenaline would stimulate both types of adrenoceptors.

Numerous studies, using drugs and more recently molecular genetic tools, have by now not only confirmed Ahlquist's suggestion but actually provided the molecular structures of adrenoceptors and the mechanisms that link occupation of the receptors at the surface of the target cells to processes inside those cells. There are 9 different adrenoceptors in humans— $\alpha 1A$, $\alpha 1B$, $\alpha 1D$, $\alpha 2A$, $\alpha 2B$, $\alpha 2C$, $\beta 1$, $\beta 2$, and $\beta 3$.

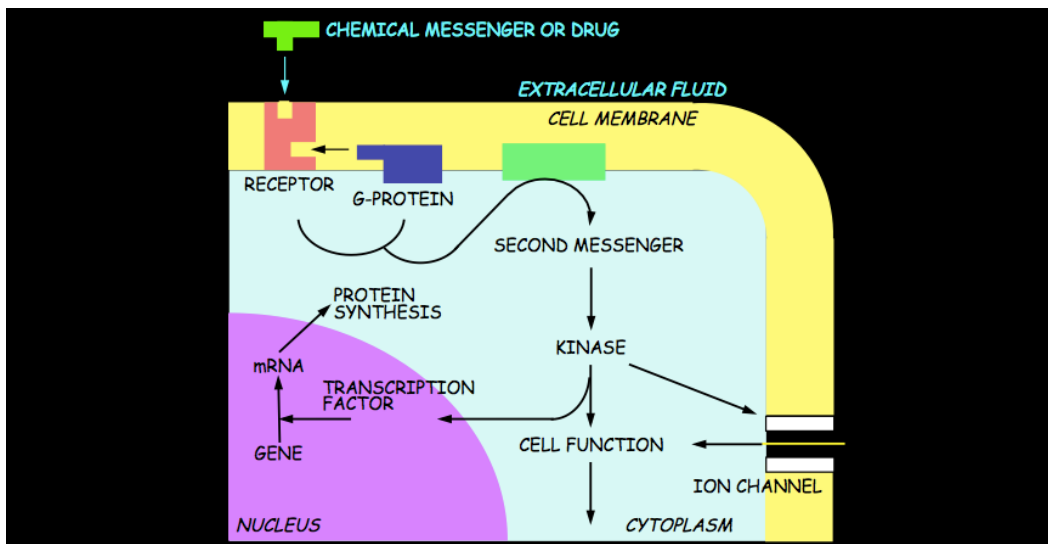

Overview of intracellular events after occupation of a G-protein-coupled receptor.

The discovery of adrenoceptors led to the development of novel, highly successful drugs to treat many common and important disorders, such as hypertension, abnormal heart rhythms, coronary artery disease, and heart failure. For the development of beta-adrenoceptor blockers, which remain key agents in the treatment of hypertension, angina pectoris, and abnormal heart rhythms, Sir James Black shared the Nobel Prize for Physiology or Medicine in 1988.

Adrenoceptors such as beta adrenoceptors in the cell membrane transmit information via specific “G proteins” (the “G” standing for guanine-nucleotide-regulatory proteins). The G proteins are located near the receptors on the inner portion of the cell membrane. For the

discovery of G proteins and their significance in cellular activation by adrenaline, Alfred G. Gilman and Martin Rodbell shared the Nobel Prize in Medicine in 1994.

Describing to an audience of colleagues his reaction to the news that he had won a Nobel Prize, as reported in the Washington Post, Gilman quipped, “First, I secreted a hell of a lot of adrenaline and then that reached my adrenergic receptors and they responded via the G proteins.”

In the liver, adrenaline liberates the vital metabolic fuel, glucose. This is a major way that adrenaline increases blood glucose levels. The release of glucose by adrenaline takes place partly by stimulating the breakdown of glycogen to form glucose in the liver. The breakdown of glycogen, in turn, involves a rather involved cascade of biochemical events. For this cascade to begin requires formation of a messenger substance inside the cells, cyclic adenosine monophosphate (cAMP). The discovery of cAMP, the first identified intracellular messenger ("second messenger," the first being the hormone itself, in this case adrenaline), depended on studies of the fractions of cell homogenates that were required for the hormonal effects of adrenaline and another hormone, glucagon, in the liver. For the discovery of cAMP, E. W. Sutherland received a 1971 Nobel Prize.

Medical textbooks often include imposing-looking charts that list the numerous types and subtypes of adrenoceptors and dopamine

receptors. The remarkable array of receptors contrasts starkly with the small family of chemicals that reach those receptors. The multiplicity of receptors for catecholamines probably follows the principle of natural selection favoring the evolution of multiple effectors.

Frau Schwandt's Cold

In the early 1960s, chemists of a German drug company came up with what they thought would be an effective treatment for nasal congestion.

The drug, clonidine, which has an imidazoline chemical structure, constricted blood vessels in a manner similar to phenylephrine, the alpha-1 adrenoceptor agonist sold as NeoSynephrine, but with a longer duration of vasoconstrictor action.

In 1962, the secretary to the medical director, a Frau Schwandt, came down with a bad cold, and the medical director applied a dilute solution of clonidine to the mucus membranes of her nose. Soon after, Frau Schwandt fell asleep. She didn't wake up until the next day, and her blood pressure fell substantially.

It was found that clonidine enters the central nervous system, producing sedation and dropping sympathetic nervous system outflows to the cardiovascular system. The company creatively redirected its marketing strategy, and the drug was developed and is

still marketed (as Catapres™) for treating hypertension. The drug has also been used successfully to treat conditions as diverse as alcohol and opiate withdrawal, baroreflex failure, and attention deficit hyperactivity disorder.

Researchers have not settled yet on the extents to which clonidine works in humans by stimulating alpha-2 adrenoceptors, imidazoline receptors, or both.

Ironically, the active ingredient in NeoSynephrine 12-hour nose spray is not phenylephrine but oxymetazoline, another imidazoline that does not enter the central nervous system as does clonidine.

STRESS, DISTRESS, AND THE ANS

Stress and Allostatic Load

There are many definitions of stress. One is in terms of homeostasis and negative feedback loops. According to this definition, stress is a condition in which the brain senses a challenge to physical or mental stability that leads to altered activities of body systems to meet that challenge.

Stress can be viewed as a condition in which the brain notes a discrepancy between information about the “inner world” and instructions for responding.

According to the concept of homeostasis, the brain coordinates body systems, with the aim of keeping values for key internal variables within bounds. According to the more recent concept of allostasis, the acceptable bounds change according to circumstances.

A low-grade fever when you have the flu is an example of allostasis.

Anyone who has had a bad cold with a low-grade fever for a few days knows from personal experience what allostasis is. Your core temperature is higher, your pulse rate is faster, you lose your appetite, you curl up in bed, you sleep more, you withdraw socially, and you

become cranky. You are “not yourself.” When you have an acute illness like this, the monitored variables of the inner world do not change in a completely uncontrolled way. For instance, your core temperature is regulated; but the virus somehow resets the thermostat. Once you recover and are back to your “old self,” all the homeostatic settings return to those before the acute illness, with no damage done.

But suppose the low-grade fever and other symptoms and signs don’t resolve so quickly. Maybe they persist or worsen over weeks or months. Then you become enfeebled, bedridden, disabled, disheveled, and disheartened. You undergo blood tests, scans, biopsies, hospitalizations, surgeries, treatments, complications, and rehabilitation. The incomplete recovery reflects effects of allostatic load. To patients with dysautonomias, this scenario probably sounds all too familiar.

Allostatic load refers to effects of prolonged activation of effectors involved in allostasis. Allostatic load is like the wear and tear on your furnace as it cycles on and off during the winter. If you turned the thermostat way up, the furnace would be on more of the time, and there would be more wear and tear on its components.

If you not only turned the thermostat up but also left a large window open for the entire winter, there could be enough wear and tear on the furnace that it would fail completely. Let’s consider this a bit more.

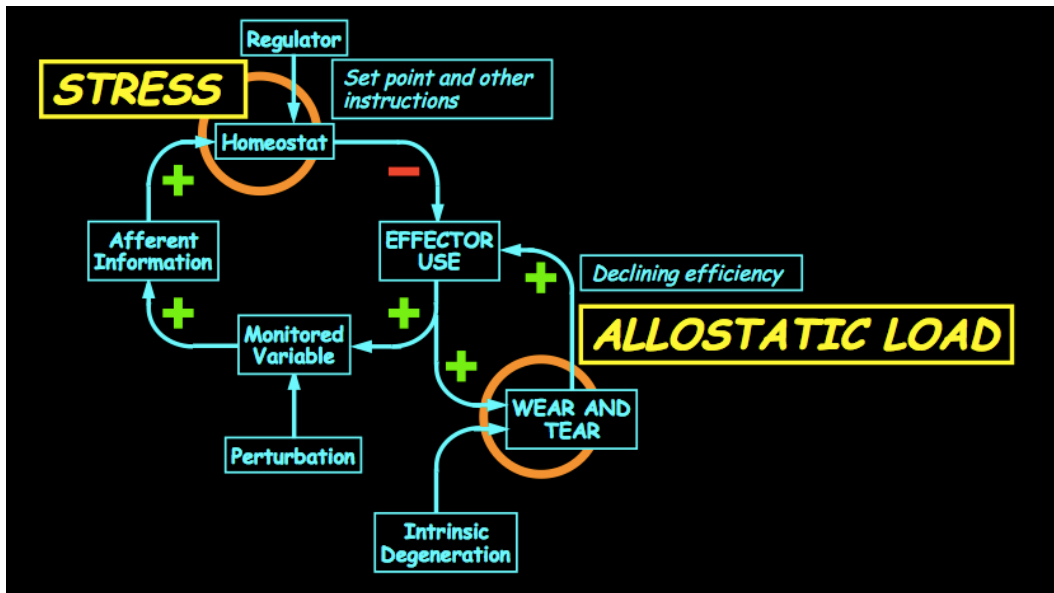

Homeostatic definitions of stress and allostatic load

Because of the wear and tear, the efficiency of the furnace declines. When the efficiency declines, then because of the negative feedback loop, the furnace is on more of the time. Because the furnace is on more of the time, there is more wear and tear, and the efficiency declines further. This is an example of a positive feedback loop. The transition from a negative feedback loop to a positive feedback loop is a transition from a stable to an unstable internal environment and the end of homeostasis.

Allostatic load links stress with degenerative diseases. Activation of effectors to counter threats to homeostasis produces wear and tear on

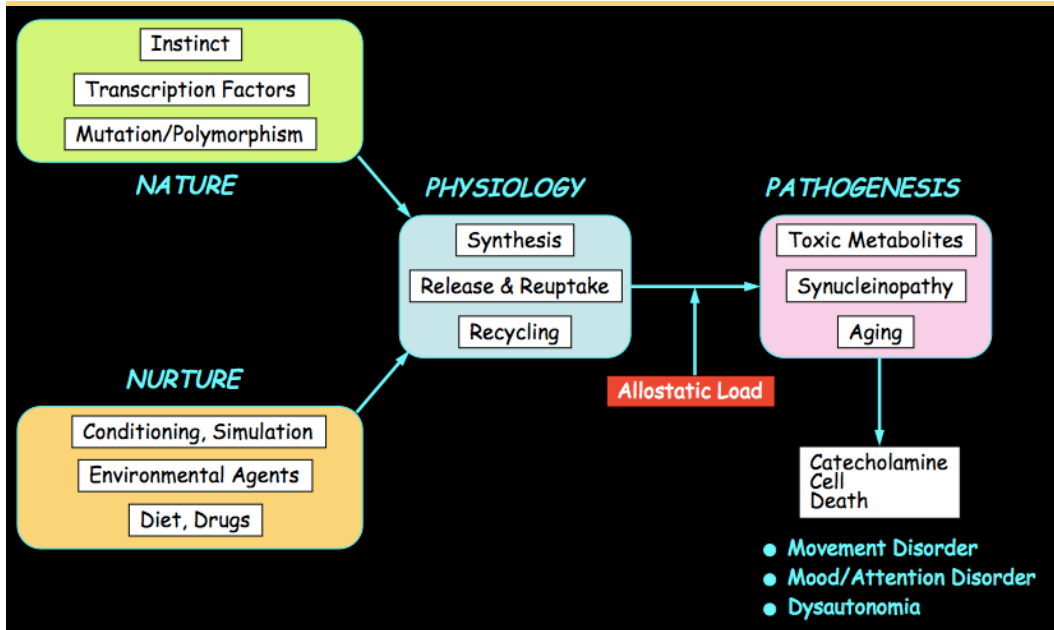

Where allostatic load fits in the area of diseases involving loss of catecholamine neurons.

the organs determining the level of the monitored variable and on the effectors themselves.

Stress can be viewed as a condition in which the brain notes a discrepancy between information about the “inner world” and instructions for responding. Allostatic load corresponds to long-term wear and tear.

Wear and tear, combined with planned obsolescence, decreases

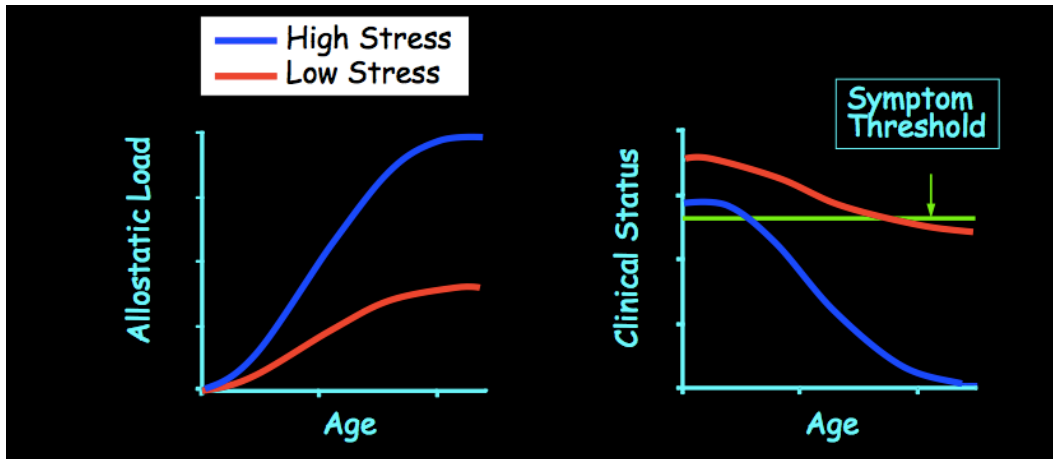

Computer-generated curves can relate clinical status to aging-related accumulation of allostatic load.

effector efficiency. The same perturbation then results in greater wear and tear and further decreases effector efficiency. Eventually, even with the effectors activated continuously, the monitored variable drifts from the allostatic setting. Finally, when the effectors fail, the organism can no longer mount a stress response at all.

Differential SNS & SAS Responses to Stressors

Differential plasma epinephrine (EPI, adrenaline) and norepinephrine (NE) responses across different stressors provide strong evidence that there is no monolithic sympathoadrenal response to all stressors.

The sympathetic adrenergic system (SAS) is very sensitive to

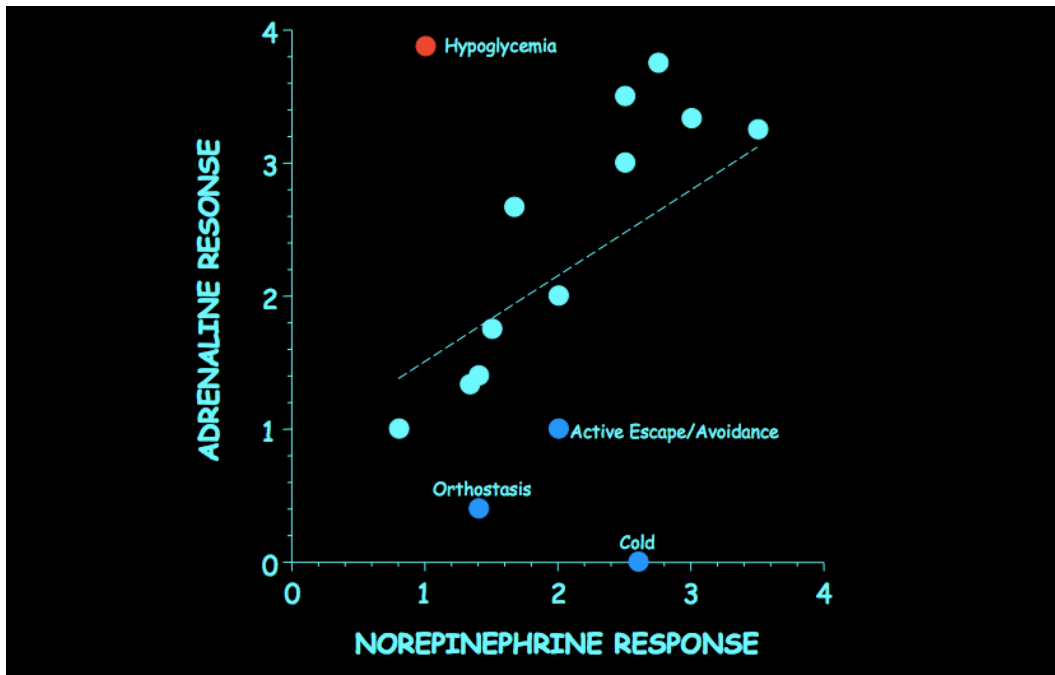

Adrenaline and norepinephrine responses to some stressors change differentially.

decreases in glucose availability, such as from insulin-induced hypoglycemia, and to emotional distress. Indeed, increased plasma EPI is probably the most sensitive index of distress.

The sympathetic noradrenergic system (SNS) is very sensitive to cold exposure, isometric or mild exercise, active avoidance or escape behavior, and orthostasis (upright posture).

Plasma EPI responses across stressors are more closely tied to responses of the hypothalamic-pituitary-adrenocortical (HPA) axis

than to responses of the SNS. One can conceptualize the existence of a unitary adrenal (adrenocortical/adrenomedullary) system just as well as a unitary sympathoadrenal system.

Distress

Non-circular definitions are required to enable experimental testing about the health consequences of distress.

A non-circular definition of distress is that it is a form of stress with additional characteristics—consciousness, aversiveness, observable signs, and adrenal gland activation. Each of these aspects receives attention below.

Consciousness

The occurrence of stress does not require consciousness. In contrast, distress does require consciousness, because distress involves not only a challenge to homeostasis but also a perception by the organism that homeostatic mechanisms may not suffice—that is, interpretation of afferent information and simulation of future events. An organism experiences distress when it perceives the inadequacy of compensatory adjustments to either a psychological or physiological stressor.

Aversiveness

Distress is negatively reinforcing and motivates escape and avoidance learning. Distressed organisms avoid situations that are perceived as likely to reproduce the same aversive experience.

The experience of distress would be expected to enhance vigilance behavior and long-term memory of the distressing event. All these are adaptive adjustments that must have offered tremendous survival advantages in evolution. In considering potential long-term health consequences of distress, such as post-traumatic stress disorder, one must bear in mind its important survival advantages.

Most animals can react instinctively not only to a stressor but also to symbolic substitutes that resemble the natural stimulus. The plasticity afforded by learning decreases the likelihood of inappropriate instinctive responses to symbolic cues. Even primitive animals have can learn to withdraw or escape from noxious stimuli or to habituate after prolonged or repeated exposure to a stimulus.

Classical (or Pavlovian) conditioning represents a refinement of these responses, in that habituation and sensitization are forms of “non-associative” learning, where the organism learns about single stimuli, whereas classical conditioning (and operant conditioning, to be discussed shortly) involves learned associations between stimuli.

Instrumental, or operant, conditioning, represents a more advanced

form of learning that requires a cerebral cortex. The conditioning is “operant” in that the individual’s behavior operates on the environment, determining the occurrence of reinforcement (reward); and the conditioning is “instrumental” in that the learning is a means to an end, since the occurrence of reinforcement depends on the behavior. Operant conditioning therefore differs from Pavlovian conditioning, in which the delivery of the reinforcement occurs independently of the individual’s behavior.

If an organism experienced distress consistently in a given situation, subsequent perception of re-exposure to the situation could elicit distress as a classically conditioned response. Situations evoking distress typically involve a complex interplay of classically conditioned and operantly conditioned behaviors, coupled with skeletal muscle and autonomic responses.

Instinctively Communicated Signs

A third characteristic of distress is evocation of signs that others can interpret as indicating the emotional state and intent of the organism. Perceptions of signs of distress by other members of the species elicit involuntary, instinctive responses. Even in humans, the fiercest combat usually ends abruptly when one side shows a universally understood sign of surrender and submission.

One such sign is waving a white flag—perhaps because of an

instinctive association of pallor with defeat. In English, “wan,” “pallid, and “pale” refer not only to skin turning white but also to weakness or feebleness. In contrast, waving a red flag is taken as an incitement and as an indicator of danger. We turn white with fright but red with rage.

The communication value of external signs of distress helps to explain the continued elaboration of observable components of distress responses in modern society, despite the relative rarity of true fight-or-flight reactions in humans. During the course of human evolution, these signs originally may have been by-products of genetically determined neurocirculatory adjustments supporting fleeing and fighting. In modern society, they continue to serve important signal functions.

Adrenal Activation

A fourth characteristic of distress is adrenal gland activation. This involves enhanced release of catecholamines from the adrenal medulla and of glucocorticoids from the adrenal cortex.

Plasma levels of EPI constitute an extraordinarily rapid and sensitive chemical index of this activation and therefore of experienced distress. The EPI response is so rapid that when an animal is killed by decapitation, arterial EPI levels are increased by about 80-fold, while glucocorticoid levels are unchanged.

Cannon viewed the neural and hormonal components of the “sympathico-adrenal” system as functioning as a unit to preserve homeostasis in emergencies. A more modern view holds that it is specifically the adrenomedullary hormonal component that characterizes distress, while sympathetic noradrenergic system outflows can increase, decrease, or stay the same, depending partly on whether there is a locomotor response (e.g., escape behavior), which entails increased skeletal muscle sympathetic outflows.

Just as there are relatively specific responses to orthostasis, altered environmental temperature, glucoprivation, salt deprivation, and so forth, there are also relatively specific distress responses, so that “fight” is not the same as “flight,” “fright,” “fume,” “fret,” or “defeat.”

“Eustress” Revisited: Adaptation and Resilience

Organisms have capabilities to habituate, anticipate, heal, regenerate, and in general increase resilience. These processes may operate at multiple sites within homeostatic loops to increase the useful life of the effectors for the same amount of chronic exposure to a stressor.

Defining distress and “eustress” (“good stress”) solely in terms of pathologic outcomes is circular and therefore unproductive scientifically. One can conceive of a non-circular definition of

eustress that is a kind of mirror image of the non-circular definition of distress. Just as distress is negatively reinforcing, motivates escape and avoidance behavior, and enhances vigilance, eustress is positively reinforcing, motivates approach and appetitive behavior, and enhances self-centeredness. Both distress and eustress have offered survival advantages in evolution, but either can be pathogenic in the setting of modern humanity. That is, neither may be only good or only bad for health. Just as modern-day pathologic consequences of distress are thought to include panic/anxiety, melancholic depression, or post-traumatic stress disorder, pathologic consequences of eustress might include drug and alcohol abuse, sex offenses, gambling and other risk-taking behaviors, and over-eating.

With repeated exposure to a stressor, the magnitude of the response decreases. Habituation is a characteristic of even primitive animals. The term, dishabituation, is used to refer to a return to the initial magnitude of response after habituation has taken place. A related phenomenon is exaggerated responsiveness of adapted organisms to a novel (“heterotypic”) stressor.

Organisms can protect and repair themselves after stress and even learn to anticipate and proactively make “feed-forward” adjustments that mitigate damage from future stress exposures. The concept is emerging that certain aspects of lifestyle, such as exercise training and some psychological interventions, enhance resilience. There is evidence that repeated exposures may increase resilience to

heterotypic stressors.

Biblical Lie Detection

Adrenaline produces marked effects on many body functions. These effects have been recognized throughout human history.

The Bible contains a unique and remarkable instance of trial by ordeal and “lie detection”—actually distress detection. This was in the case of a woman accused by her husband of adultery. She would be brought to the priest, who would conduct the trial according to a specific ritual. The key sign of guilt was that upon being forced to drink “waters of bitterness,” consisting of water and dust from the floor of the tabernacle. The priest would incant, “If thou has gone aside, being under thy husband, and if thou be defiled . . . this water that causeth the curse shall go into thy bowels, and make thy belly to swell, and thy thigh to fall away” (Numbers 5:19-21). The accused woman would reply, “Amen, Amen” (the first use of the term in the Bible). The woman would then drink the test potion. If she had been unfaithful, her belly would swell.

Why would the belly swelling be a sign of distress and therefore of guilt? Adrenaline potently relaxes smooth muscle of the gastrointestinal tract.

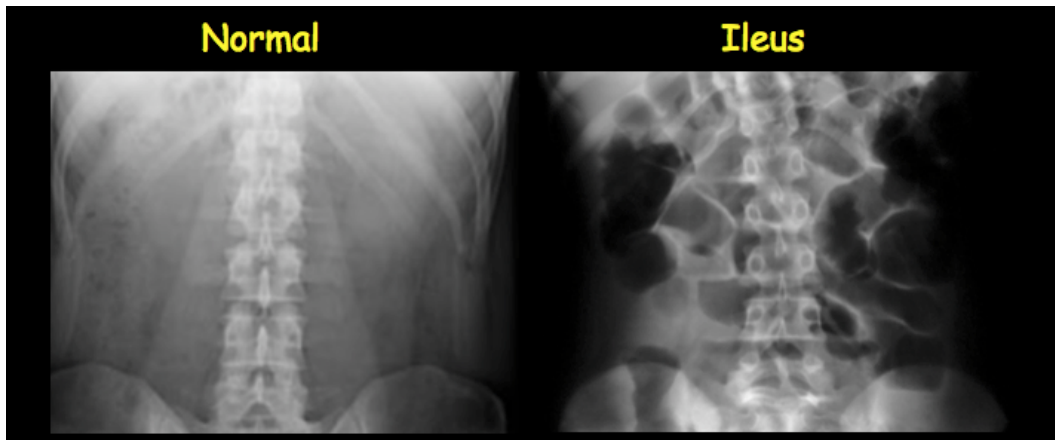

Abdominal distention from dilation of loops of bowel by air

Indeed, this relaxation provided the basis for the first successful method, introduced by Walter B. Cannon, for detecting adrenaline release during emotional distress. Cannon drew blood from a cat exposed to a barking dog. This evoked release into the cat's blood of a substance that relaxed a strip of gut tissue but contracted a strip of blood vessel tissue. The pattern of relaxation of gut tissue but contraction of blood vessel tissue was the first experimental finding indicating release by emotional distress. The woman would have a form of functional ileus (decreased propulsion of gut contents). In this setting, a non-palatable liquid would not pass through the gut, and the belly would swell.

It is not widely appreciated that high circulating levels of catecholamines can produce ileus, with distended loops of bowel

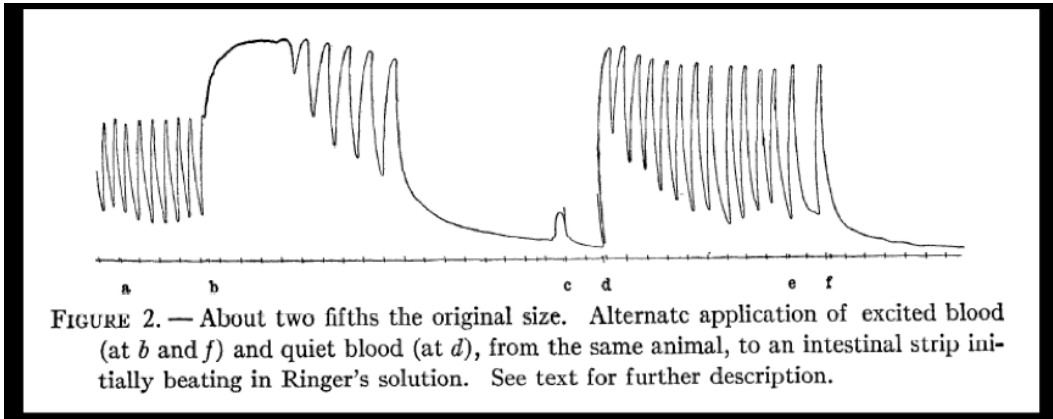

Cannon's demonstration of relaxation of an intestinal strip upon application of blood from a cat exposed to a barking dog—the first published evidence for adrenaline release during distress.

resulting in the appearance of abdominal swelling. Ileus can even be an initial manifestation of pheochromocytoma, a tumor that secretes catecholamines into the bloodstream.

What would be the meaning of the guilty woman's thigh "falling away"? If the accused woman were innocent, she would be able to "retain seed." This might mean she would be able to conceive. It is well known that in distressing circumstances women can have anovulatory periods or stop menstruating. Both of the key signs of guilt in the biblical trial by ordeal therefore can be understood in terms of bodily effects of distress.

The 23rd Psalm

Psalm 23, a triumph of literature, has the core concept of calm confidence, because “The Lord is my shepherd...” Right in the middle of the psalm is the well known verse, “Yea, though I walk through the valley of the shadow of death, I fear no evil: for thou art with me; thy rod and thy staff they comfort me. Thou preparast a table before me in the presence of mine enemies...”

What does setting a table in the presence of ones enemies have to do with the theme of the psalm? Because adrenaline decreases the ability of gut smooth muscle to contract. Given the inability to digest during distress, if you were able to eat in the presence of your enemies, you could not be distressed. The passage about setting a table in the presence of enemies therefore does indeed fit with the theme of the psalm: Because the “Lord is my shepherd . . . I fear no evil.”

Several instances occur in the Old Testament narrative in which a distressed individual cannot eat. Aaron is unable to eat the sacrifice, his priestly duty, after witnessing his sons’ death. Hannah cannot eat when tormented by her nemesis Peninah. Jonathan eats no food after Saul obsesses about David. Ahab does not eat out of jealousy of Elijah. Job in his suffering “abhorreth bread, and his soul dainty meat” (Job 33:20).

A Chicken with Its Head Cut Off

You probably have heard the phrase, “running around like a chicken with its head cut off.” If you were to chop off a chicken's head, wouldn't the blood spurt out and the animal rapidly lose consciousness and become motionless? Actually, no. A remarkable amount of blood remains in the body, as the severed trunk oozes blood. If you guillotined a laboratory rat, it would shriek for several seconds. To obtain “trunk blood,” you might have to squeeze it out!

Adrenaline's actions promoting hemostasis explain this macabre scene. Chopping off an animal's head instantly evokes drastic release of catecholamines into the bloodstream by the adrenal gland. So much adrenaline pours out, so fast, that “trunk blood,” even obtained immediately after decapitation, contains about a hundred times the resting concentration of adrenaline. The surge of adrenaline constricts blood vessels and promotes platelet plugging to such an extent that chickens actually do run around with their heads cut off.

When adrenaline was patented about the turn of the 20th century, the drug's main intended use was to control bleeding. It is worth keeping in mind that in the setting of a heart attack due to a blood clot in a coronary artery, the associated emotional distress, resulting in adrenaline release, could be lethal by evoking a positive feedback loop. Because the class of drugs called benzodiazepines inhibit adrenaline release, treatment with a benzodiazepine may be considered for patients with acute myocardial infarction who manifest signs of emotional distress.

No Sweat

Not only the sympathetic cholinergic system (SCS) but also the sympathetic adrenergic system (SAS) contributes to emotional sweating.

Several years ago our Nurse Practitioner was going out for the evening and was giving instructions to the babysitter. Her daughter had frequent asthma attacks, and so she wanted to demonstrate how to use an EpiPen™ in case there was an emergency. For practice she had a dummy pen, which could be reset by clicking the top—somewhat like clicking the top of a ball point pen. She showed the babysitter how easy it is to use and EpiPen™—just pull off the blue safety release and jab with the orange needle end against the outer thigh and hold it in place for about 10 seconds to deliver the adrenaline. But when she jabbed herself, to her surprise she felt a sharp needle prick, which was odd for the blunt ended dummy pen; and when she pulled the pen from her thigh, she noticed that she couldn't reset the pen by clicking the top.

That was when a wave of sweat began to spread over her body. Within several seconds her clothes were drenched. She also noticed some hyperventilation and jitteriness and realized that instead of a dummy pen she had used a real EpiPen™ and had injected adrenaline into her leg.



An EpiPen™ delivers 3 mg of adrenaline over about 10 seconds.

As a going away gift she gave me an EpiPen™, which I keep on display in my office.

Snow White

Pallor is probably the most obvious among the many effects of adrenaline as a hormone. The pallor results from constriction of blood vessels in the skin. Constriction of skin blood vessels minimizes blood loss from physical trauma and also promotes increased blood temperature by interfering with heat loss from the blood delivered to the skin's surface.

The blood vessel constricting action of adrenaline varies remarkably with the particular body organ. Just a few centimeters below the skin,

in the skeletal muscle, adrenaline tends to dilate the blood vessels. This dilation redistributes blood toward the skeletal muscle, as would be appropriate in preparation for a “fight or flight” response. I carried out an experiment once that involved infusion of adrenaline into the brachial artery of normal volunteers. The brachial artery carries the blood to the forearm and hand. The infusion produced obvious pallor of the hands, yet total forearm blood flow, determined mainly by the blood vessels in skeletal muscle, actually increased in some people.

Adrenaline also constricts blood vessels in the gut and kidneys. In contrast, adrenaline exerts relatively small direct effects on the blood vessels in the heart muscle, the lungs, and the brain. Adrenaline's net effect on the distribution of the blood ejected by the heart therefore is to shunt blood away from the skin and toward skeletal muscle, while maintaining blood flow to the three vital organs.

Adrenaline-induced pallor is an instinctively communicated sign of terror. You turn “white with fright” and look “pale as a ghost.” You seem “ashen,” “wan,” and “pallid,” indicating not only pallor but also sickness. Your skin becomes “pasty,” and you “blanch” as the “color drains from your face.” I think this is why waving a white flag is a universal sign of surrender. Terrorized people display their open palms to the adversary, as if submitting for inspection and confirmation physical evidence for the absence of aggressive intent. Although it is true that you can become “livid” with rage, more likely

you “burn” or “seethe,” the skin flushing hot rather than blanching cold. When enraged you “see red,” not white. In Chinese, the calligraphic characters that together mean “fear” literally denote “white face.”

In the Old Testament, Moses and Miriam, brother and sister, both turn “white as snow” in separate episodes when confronted directly by God. Miriam’s sudden pallor could have indicated an involuntary, automatic, instinctively communicated sign of terror. That sign would result from constriction of blood vessels in the skin, and the constriction would result from the local action of adrenaline.

At the same time and for the same reason that the skin becomes pale under the influence of adrenaline, the skin also turns cold. When the blood vessels in the skin constrict, delivery of blood to the skin decreases. Because the arteries carry blood to the skin, the largest organ of the body, at the core temperature, which typically exceeds the ambient temperature, the temperature of the skin falls toward that of the cooler environment. You develop “cold feet.”

People withdrawing suddenly from an addictive drug go “cold turkey.” The origin of this phrase is obscure. Perhaps it refers to simultaneous constriction of skin blood vessels and development of goosebumps, both of which are produced by adrenaline as a hormone and by locally released norepinephrine as a neurotransmitter.

Tremulousness is another instinctively communicated sign of fear to the point of panic, appreciated by writers since ancient times. The Old Testament contains numerous references to trembling as a sign of emotional upset. For instance, Isaac trembles as an automatic, immediate response, when he realizes that he has been deceived into giving his paternal blessing to Jacob, not Esau. Both adrenaline released from the adrenal gland and norepinephrine released from sympathetic nerves can produce this ineffectual, rhythmic skeletal muscle contraction. To “shudder,” “quiver,” “quake,” and “quail” not only mean to tremble but to do so in fear or uncertainty. Indeed, I have observed that people receiving an infusion of yohimbine, which releases norepinephrine from sympathetic nerves and adrenaline from the adrenal gland, can have sufficient trembling of the jaw that the teeth chatter.

Trembling and shivering during distress both probably reflect activation of the sympathetic noradrenergic system, since, as Cannon first showed, surgical inactivation of the adrenal glands augments, rather than prevents, shivering of animals exposed to cold. Perhaps predictably, patients with benign essential tremor can obtain relief by treatment with a beta-adrenoceptor blocker, which attenuates some of the effects of both norepinephrine and adrenaline. Musicians with stage fright or performance anxiety often take a beta-blocker before concerts. A friend of mine, a professional cellist, told me that not only did several of his colleagues take a beta-blocker prophylactically before a concert but also that he could tell when a musician had done

so. The performance would be technically highly accurate but with a subtle emotional restraint. The performance would seem detached.

StressDots

StressCards, StressDots, StressRulers, BioDots, StressPens, StressPoints, StressControl cards, and similar items all include a shiny black patch of plastic. You press a fingertip on the patch for a minute or so, and the color changes. Depending on the color, you are “stressed,” neutral, or relaxed. You are supposed to try to change the color to that corresponding to being relaxed.

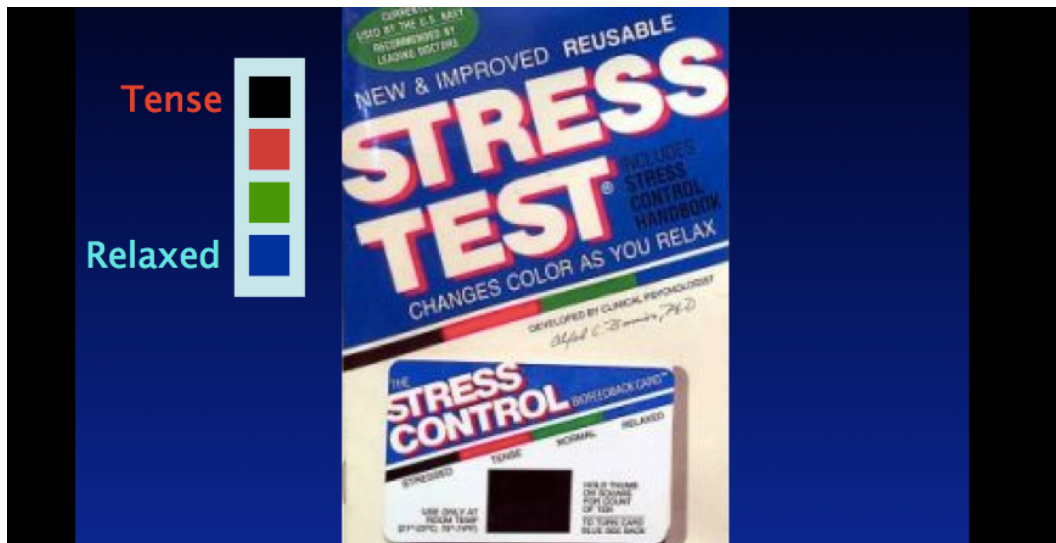

Adrenaline decreases skin temperature.

StressDots and similar items work by the same principle. The key is the liquid crystal patch or dot, which changes color as the temperature

changes. When you learn to control your “stress,” you really learn to increase your skin temperature—a kind of biofeedback.

Why should skin temperature provide a gauge of stress? When you are in distress, you release adrenaline into the bloodstream. The bloodstream delivers adrenaline to all organs of the body, and adrenaline tightens blood vessels in the skin. When the skin blood flow decreases due to blood vessel constriction, the skin temperature falls toward that of the usually much cooler room temperature. The StressCard reports that you are “stressed.”

The Heart of the Bible

All emotions entail changes in heart functions, a fact recognized by one of the giants in the history of medicine and physiology, William Harvey—the same William Harvey who in 1628 described the circulation of the blood for the first time. In exactly the book in which he reported his monumental discovery, *On the Circulation of the Blood* (the English translation of the Latin title), he also promulgated one of the founding ideas of psychosomatic medicine and neurocardiology, “For every affection of the mind that is attended with either pain or pleasure, hope or fear, is the cause of an agitation whose influence extends to the heart” (Harvey, 1628).

The notion that the heart functions as a pump is new in medical history. For fourteen centuries, until Harvey's description of the

circulation of the blood, practitioners following the teachings of Galen viewed the heart as a furnace, imbuing the blood with the “vital spirit,” and not as a pump.

In modern English we have many words and phrases that refer to the heart in the biblical sense—weak of heart, hard of heart, sick of heart, faint of heart, strong of heart, change of heart, heartfelt, take heart, take to heart, lay to heart, lose heart, have a heart, halfhearted, wholehearted, warmhearted, coldhearted, and so forth.

By now most people know that injected adrenaline increases the force and rate of the heartbeat. Every emergency that poses a global threat to the organism, from cold exposure to low blood sugar to low blood pressure from hemorrhage to emotional distress, leads to adrenaline release into the bloodstream. The concept that adrenaline functions as a powerful hormone in emergencies can be credited to one man-- Walter B. Cannon. Many of his most important findings, including those demonstrating the role of adrenaline in the tachycardia (fast heart rate) attending emergencies, appeared in the American Journal of Physiology (AJP) in the 1920s. Indeed, his first article was published in the first issue of the AJP, in 1898, before he had obtained his medical degree. As Abel was the father of American pharmacology, Cannon was the father of American physiology.

The sympathetic nerve supply to the heart resembles a complex cat's cradle of strings, distributed in fibrils surrounding the heart muscle

cells. Except for unusual situations such as severe exercise, in healthy people the main medium for regulation of the force and rate of the heartbeat is not adrenaline the hormone but norepinephrine and acetylcholine released from the body's "heartstrings."

At a lower blood level than that required to increase the force and rate of the heartbeat, adrenaline decreases the total peripheral resistance to blood flow in the body, mainly by relaxing blood vessels in skeletal muscle. Exactly why the same chemical, working via the same types of receptors and identified intracellular mechanisms, relaxes smooth muscle in the walls of blood vessels in skeletal muscle while contracting smooth muscle in the heart remains unclear.

An overdose of adrenaline is, of course, highly dangerous. Animals given overdoses of adrenaline die of blood seeping into and clogging the air sacs in the lungs. At first, adrenaline drastically stimulates the heart, and the force and rate of the heartbeat increase remarkably. The heart muscle cells can actually rupture, just like overstrained skeletal muscle. A peculiar type of heart cell death, called contraction band necrosis, then develops. The blood backs up into the lungs because of failure of the heart to contract further--in essence, a form of overwhelming and rapidly fatal heart failure.

Since adrenaline doesn't penetrate the blood-brain barrier, little of adrenaline in the bloodstream actually reaches most sites in the central nervous system. Then how can adrenaline produce such clear effects

on the intensity of emotional experiences? One way may be by the cognitions people have about the state of their inner world, such as rapid pulse rate, increased force of the heartbeat, pallor, sweating, trembling, and increased ventilation. According to this view, treatment with a drug that blocks these effects, without altering adrenaline levels themselves, could prevent the emotional-physical positive feedback loop. As noted above, such treatment does seem to work, sometimes remarkably well, in people with performance anxiety or stage fright. It is also possible that high catecholamine levels could alter levels of chemicals that do penetrate the blood-brain barrier; or that circulating adrenaline can reach some central nervous system sites because of local deficiencies in the blood-brain barrier.

The Sleeper Hold

My grandmother and I used to watch professional wrestling on TV. Propped in bed, she would cheer on her hero, Antonino Rocca, the barefoot master of the flying dropkick, and hiss at Skull Murphy, who was notorious for butting opponents with his shaved, vaselined head.

In professional wrestling you can win by three smacks by the referee on the tarp, by disqualification, or by submission. In particular, in the “sleeper hold,” the attacker unexpectedly circles the victim and wraps arms around the victim’s neck, as if to choke from behind; but instead of choking the victim, the attacker massages both sides of the

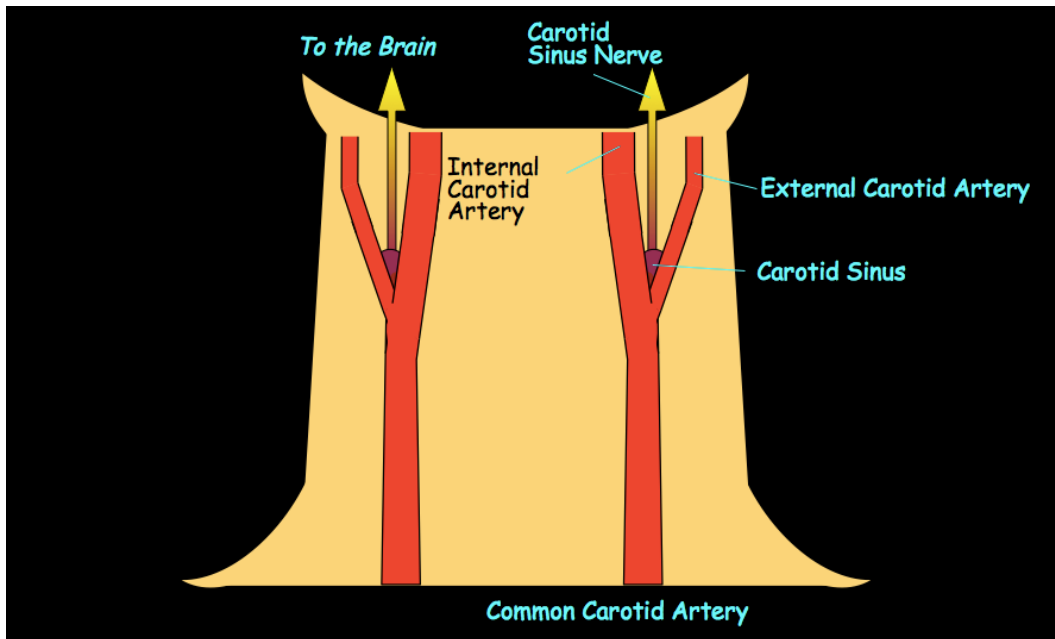

In humans distortion receptors, baroreceptors, in the carotid sinus send afferent traffic to the brainstem.

opponent's neck vigorously below the angles of the jaw. After several seconds of this massaging, the opponent slumps to the mat unconscious; that ends the bout.

Over the years I came to question the veracity of professional wrestling, but I do think there is a kernel of truth to the sleeper hold.

This is because specialized distortion receptors called baroreceptors lie in the carotid sinus, in the crotch of the “Y” where the common carotid arteries, the main arteries delivering blood to the head, fork in

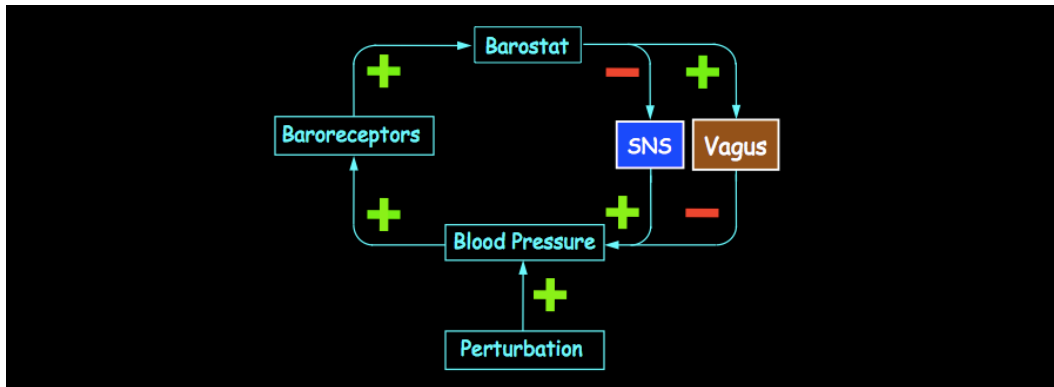

Arterial baroreceptor activation produces opposite effects on sympathetic noradrenergic system and vagal outflows.

the upper neck. When the blood pressure increases, the wall of the carotid sinus on each side expands, and this stimulates the baroreceptors in the artery wall. Nerve traffic to the brain then increases in the carotid sinus nerve and reaches a particular cluster of cells in the lower brainstem—the nucleus of the solitary tract, or NTS. Activation of the NTS cells leads to a rapid, reflexive fall in pulse rate, relaxation of blood vessels, and a less forceful heartbeat. The blood pressure and consequently the blood flow to the brainstem decreases, and the victim loses consciousness.

The story of the sleeper hold teaches that one of the most important examples of negative feedback regulation mediated by the autonomic nervous system is the arterial baroreflex. In the arterial baroreflex (from the Greek word for weight and the Latin word for bending

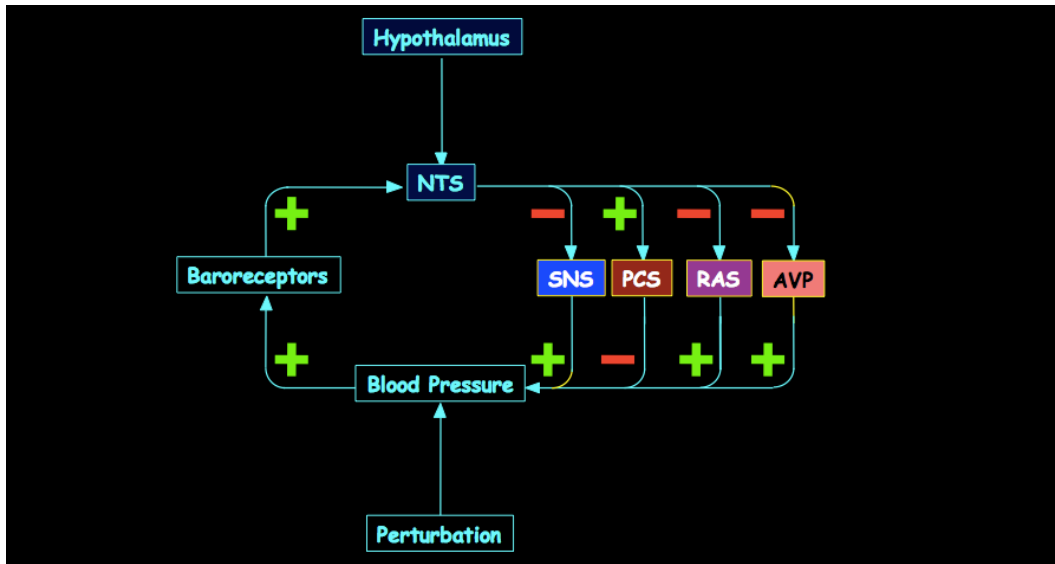

Alterations in blood pressure evoke reflexive changes in activities of several effectors.

back), when blood pressure increases, this causes the distortion receptors in the walls of arteries such as in the carotid sinus to fire. The increase in afferent nerve traffic to the brainstem, especially via the carotid sinus nerve, results in a reflex, the baroreflex. Sympathetic noradrenergic system (SNS) activity decreases, tending to relax the blood vessels and decrease the force of heart contraction. At about the same time, vagal parasympathetic nervous system (PNS) outflow to the heart increases, tending to decrease the heart rate. The net effect is to bring the blood pressure down. On the other hand, when blood pressure falls, the SNS is released from baroreceptor restraint, and the increased SNS outflows constrict the blood vessels and increase the rate and force of heart contraction. A sustained decrease in blood

pressure also releases the arginine vasopressin (AVP) and renin-angiotensin-aldosterone (RAS) effectors from baroreceptor restraint.

A key sign of arterial baroreflex failure is blood pressure lability.

Patients with arterial baroreflex failure sometimes have hypertension (chronic high blood pressure) or orthostatic hypotension (a fall in blood pressure when standing), but they always have labile blood pressure.

Baroreflexes

Standing up sets into motion important reflexes called the baroreflexes. Baroreflex testing is a key part of autonomic function testing.

Baroreflexes help maintain the blood pressure.

Baroreceptors are tiny distortion receptors in the walls of large blood vessels (arteries) and the heart. The term, “arterial baroreflex,” refers to the reflex that is evoked when the baroreceptors in arteries are stretched. In humans baroreceptors in the neck in the carotid sinus region, where the common carotid artery splits into the internal and external carotid arteries, seems especially important.

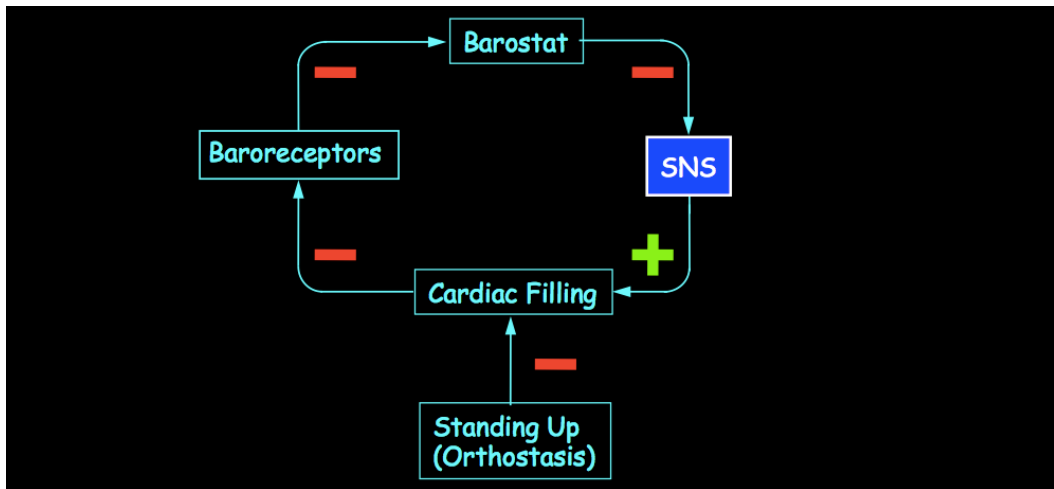

Baroreflexes involve negative feedback loops (an odd number of “-“ signs. This is a simple baroreflex diagram.

In the heart, baroreceptors are located in low pressure regions like the walls of the great veins and atria. The term, “low pressure baroreflex,” refers to the reflex that is evoked when the baroreceptors in the heart are stretched. The responses to changes in arterial pressure differ somewhat from the responses to changes in cardiac filling. No one knows what the “goals” of the baroreflexes are, but one can conceptualize that the arterial baroreflex regulates blood pressure and the low pressure baroreflex regulates blood volume.

When a person stands up, the force of gravity tends to pool blood in the legs, lower abdomen, and pelvis. This decreases the return of blood to the heart in the veins. The heart pumps out less blood.

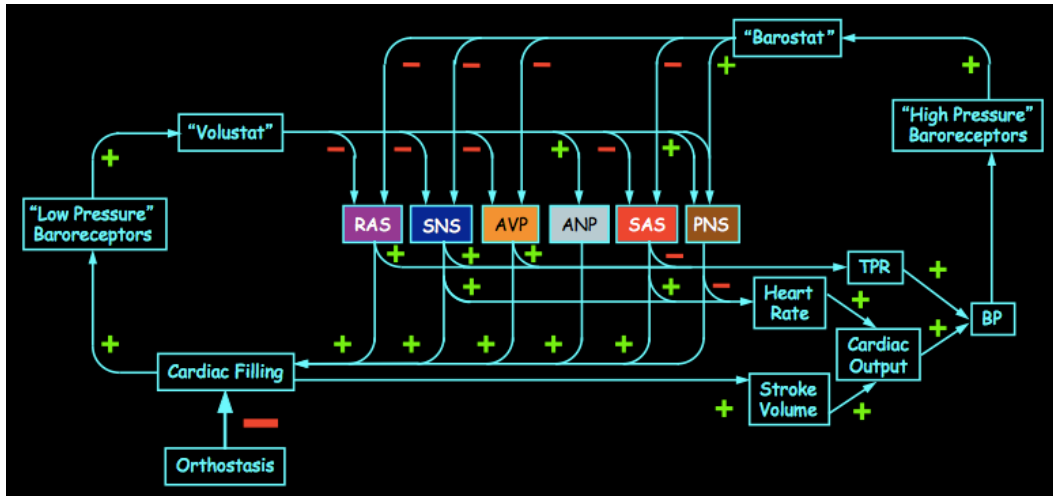

This is a more realistic depiction of baroreflex adjustments to “simply” standing up.

When the heart ejects less blood, information changes in nerves traveling from the baroreceptors to the brain. The brain responds by directing an increase in the activity of the sympathetic noradrenergic system. The sympathetic nerves release norepinephrine, and the norepinephrine activates receptors on cells in the blood vessel walls. This tightens the blood vessels, and so the total resistance to blood flow in the body increases. In other words, the total peripheral resistance increases. Even though the total amount of blood ejected by the heart per minute (cardiac output) has decreased, the average blood pressure normally is maintained, due to the increase in total peripheral resistance.

You might understand the baroreflex better by thinking about the

water pressure in a garden hose. The pressure is determined by how much the faucet is turned on and how much the nozzle is tightened. If you turned down the faucet, the pressure in the hose would decrease, and less water would come out the nozzle. If you wanted to keep the pressure in the hose the same, you could tighten the nozzle.

Failure of the sympathetic noradrenergic system always causes orthostatic hypotension. In sympathetic noradrenergic system failure, the patient can't "tighten the nozzle."

Don't Do This at Home

When you are exposed to a decreased amount of oxygen or to an increased amount of carbon dioxide in the inhaled air (hypoxia or hypercarbia), or when the amount of acidity in your blood increases, your rate and depth of breathing increase.

This is an automatic, involuntary, unconscious response. The main effector is the phrenic nerve supplying the diaphragm.

One might reasonably argue that such a reflex qualifies as autonomic; however, since the phrenic nerve emanates from the cervical spinal cord and is not post-ganglionic (although it does contain sympathetic post-ganglionic fibers), by Langley's definition reflexive hyperventilation would not be considered to be autonomic.

On the other hand, hypoxia and hypercarbia increase activity of the

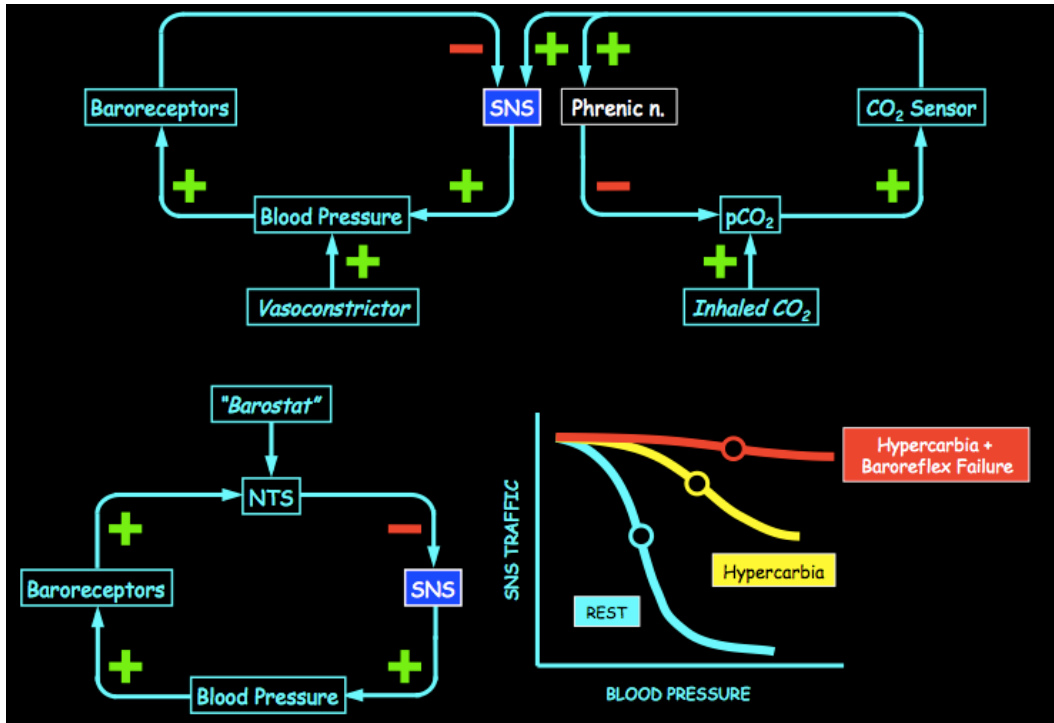

One can model chemoreflex-baroreflex interactions without or with a comparator homeostat.

sympathetic noradrenergic system (SNS). This aspect of the chemoreflex surely would be considered autonomic.

The extent of SNS stimulation is especially pronounced in the setting of baroreflex failure. One can conceptualize two types of negative feedback models predicting changes in the relationship between SNS outflow and blood pressure in the setting of hypercarbia. According to one model, inhalation of carbon dioxide stimulates brainstem

chemoreceptors, and the chemoreceptor stimulation both increases ventilation and increases SNS outflows, raising blood pressure. That is, hypercarbia shifts to the right the curve relating SNS traffic to blood pressure. Baroreceptors restrain SNS outflow, and interference with this restraint (such as by panic/anxiety) augments the SNS and pressor responses to hypercarbia.

According to another model, a metaphorical “barostat” regulates how neurons in the nucleus of the solitary tract (NTS) respond for a given amount of baroreceptor afferent traffic. Hypercarbia alters the set-point for responding, so that blood pressure is regulated at a new level (allostasis). Anxiety decreases baroreflex-sympathoneural gain, enhancing the stimulatory effects of the hypercarbia and SNS outflows and blood pressure.

Several years ago a patient evaluated at the NIH for a difficult form of dysautonomia taught me a remarkable and scary lesson about interactions among chemoreflexes, baroreflexes, and distress. The patient carried a diagnosis of “complex” sleep apnea. For this he had been treated with continuous positive airway pressure (CPAP) using a device he brought with him and used throughout his inpatient stay. The device had been modified to administer a small percent of carbon dioxide with the CPAP, to alleviate episodes of hyperventilation and agitation he had experienced with CPAP alone. Upon autonomic function testing during the day, his directly recorded brachial systolic blood pressure was about 250 mm Hg. He had marked baroreflex-

cardiovagagal failure and very high arterial plasma norepinephrine and adrenaline levels. His discharge diagnosis was extreme sympathetically mediated hypertension. A reasonable pathophysiologic explanation would be a combination of baroreflex failure due to panic/anxiety and repeated episodes of chemoreflex stimulation due to carbon dioxide self-administration.

An Amazing Cooking Experiment

Your body contains a temperature regulating system that is more efficient than that found in any man-made structure. For the brain to operate effectively requires maintaining the blood temperature within a fairly narrow range. The brain in turn keeps the blood temperature, or core temperature, about the same, via regulating activities of multiple effectors.

The thermostat in your brain receives temperature information from two sources. The first source is temperature sensors in the skin, a key interface between the outside and the inner worlds. A second source is sensors within the substance of the brain itself, which monitor the temperature of the blood. This duality corresponds to the two main determinants of heat dissipation and heat generation in the body-- evaporative loss of heat from the skin's surface and generation of heat by internal metabolic processes.

Losing body heat by evaporative sweat loss requires sweating, and

stimulation of a particular component of the automatic nervous system, called the sympathetic cholinergic system (SCS), stimulates thermoregulatory sweating. Losing body heat by evaporative heat loss also requires delivering blood to the skin surface, so that the warm blood can equilibrate with the cool outside temperature. Inhibition of nerves supplying the skin in another component of the automatic nervous system, the sympathetic noradrenergic system (SNS), relaxes the local blood vessels, distributing the blood to the skin surface.

On January 23, 1774, the amazing ability of the human body to maintain core temperature by evaporative heat loss was demonstrated experimentally for the first time. Five men, including Dr. Charles Blagden, then 26 years old, entered a room that was heated progressively with dry air. Eventually the temperature exceeded that of boiling water—an egg in the chamber roasted solid in 20 minutes. The temperature of Blagden’s exhaled breath was relatively cool compared with the external temperature in the room, “Whenever we breathed on a thermometer the quicksilver sank several degrees.” Three weeks later, Blagden reported his observations to the Royal Society of London, which published his report in its Proceedings in 1775.

In the heat chamber Blagden eventually began to experience anxiety, his pulse rate increased excessively, and he decided to end the experiment. “[At 260 degrees] I sweated, but not very profusely. For

seven minutes my breathing continued perfectly good; but after that time I began to feel an oppression in my lungs, attended with a sense of anxiety; which gradually increasing for the space of a minute, I thought it most prudent to put an end to the experiment, and immediately left the room. My pulse, counted as soon as I came into the cool air, was found to beat at the rate of 144 pulsations in a minute, which is more than double its ordinary quickness.”

Adrenaline potently constricts blood vessels in the skin and increases the generation of metabolic heat. One may speculate that the amazing cooking experiment ended when the adrenaline level in Blagden’s bloodstream reached a high enough value to constrict the blood vessels in his skin. Increased heat production and decreased evaporative cooling would have increased the core temperature, producing distress and further adrenaline release. In other words, the introduction of a positive feedback loop may have forced Blagden to call it quits.

Sweet Urine

The seventeenth century English physician Thomas Willis may have been the first scientist to note that patients with diabetes excrete sweet urine. The sweetness results from high blood levels of glucose, which is a sugar.

Adrenaline is one of the three main hormones that regulate

blood glucose levels, the other two being insulin and glucagon.

Injection of adrenaline increases the blood glucose level by accelerating the production of glucose from its storage form, glycogen, in the liver and by inhibiting the release and actions of insulin.

It was Claude Bernard, the originator of the concept of the inner world, who first showed that glucose in the bloodstream is derived not from dietary intake of sugar but from its production within body organs. Bernard isolated “glycogen” (from the Latin for “generator of sugar”) from liver tissue and demonstrated its conversion to glucose in the liver.

Puncture Diabetes

Bernard wondered whether release of glucose from the liver into the bloodstream would depend on nerves supplying the liver. He tried stimulating the vagus nerve, but this produced no effect on blood glucose. In 1849 he conducted an experiment in which he punctured the spot in the brainstem from which the vagus nerve emanated. This produced hyperglycemia. Within an hour the urine contained abundant sugar. Diabetes by *piqûre*, or puncture, has been associated with Bernard's name ever since.

Bernard thought that he had discovered a neuronal cause of diabetes. To demonstrate that trauma to the floor of the fourth ventricle released glucose from the liver by way of the vagus nerves, he cut them before the puncture. Even so, the puncture still produced hyperglycemia. He had to reject the notion of diabetes from vagus nerve stimulation, and he pursued other ways the nervous system might contribute to the release of glucose by the liver. He then found that cutting the spinal cord just above the site of exit of the splanchnic nerves, which carry pre-ganglionic fibers of the sympathetic adrenergic system to the adrenal glands, did abolish the increase in blood glucose levels consequent to puncturing the floor of the fourth ventricle. He reasoned that *piqûre* diabetes results from stimulation of sympathetic nerves supplying the liver. This was long before the discovery of the sympathetic nervous supply of fibers to the adrenal gland. Now we know that *piqûre* diabetes probably mainly results from the effects of adrenaline released into the bloodstream, although, sympathetic nerves to the liver may also contribute.

Decades later, deficiency of insulin was shown to be the culprit in juvenile-onset diabetes; however, ironically, modern research about insulin resistance in adult-onset diabetes has returned to the concept, based on Bernard's experiment, that the brain does play a role.

Lose Weight Fast!

Injected adrenaline evokes several effects that, taken together, rapidly

mobilize metabolic fuels from storage sites and burn calories. The rate of metabolism in the body as a whole increases; oxygen consumption by the heart increases; body temperature increases; stores of glycogen in the liver are broken down into the metabolic fuel, glucose; and fats are converted to free fatty acids, generating heat in the process.

Several effective weight loss drugs share the effect of augmenting occupation of receptors for catecholamines, both inside and outside the brain. Amphetamines such as phentermine increase release and inhibit reuptake of catecholamines, suppressing appetite and increasing metabolic rate. Phentermine, prescribed with fenfluramine, constituted the notorious “Fen-Phen,” which, while effective in promoting weight loss in dieters, produced harmful heart and lung side effects. Phenylpropanolamine (PPE), another sympathomimetic amine, was the active ingredient in many over-the-counter weight loss drugs, until PPE also was removed from the market. Conversely, treatment with beta-adrenoceptor blockers, which inhibit adrenaline effects, can promote weight gain. Studies have indicated a statistical association between polymorphisms of beta-adrenoceptor subtypes and obesity; and weight loss drugs are being tested that work by stimulating particular beta-adrenoceptor subtypes.

An Unusual Weight-lifting Feat

Many years ago, the Guinness Book of World Records section on weight lifting contained the following entry, “It was reported that a

hysterical 123-lb. woman, Mrs. Maxwell Rogers, lifted one end of a 3,600-lb. car which, after the collapse of a jack, had fallen on top of her son at Tampa, Florida, on April 24, 1960. She cracked some vertebrae” (Guinness Book of World Records, 1976, 669).

Apparently, Mrs. Rogers had tapped automatically into what Cannon would have called her “reservoirs of power.”

Some of Cannon’s papers described the direct effects of adrenaline in augmenting the force of skeletal muscle contraction or in antagonizing the fatigue effect of continual trains of electrical stimulation-induced excitation of skeletal muscle contraction. Researchers seem to have doubted and certainly subsequently lost interest in the direct effects of adrenaline in augmenting contraction of skeletal muscle and preventing skeletal muscle fatigue. But all would agree that emotionally distressing situations, such as that encountered by Mrs. Maxwell, temporarily enable people to perform extraordinary feats of strength and speed. Because these behaviors are automatic, involuntary, and unconscious, they probably importantly involve the autonomic nervous system.

In his *Expression of the Emotions in Man and Animals*, Charles Darwin noted the self-reinforcing, energizing effect of some emotions. He wrote, “The excited brain gives strength to the muscles, and at the same time energy to the will...Anger and joy are from the first exciting emotions, and they naturally lead, more especially the former, to energetic movements, which react on the heart and this again on the

brain.”

In the early 1960s, the psychologists Stanley Schachter and Jerome Singer, of Columbia University, studied effects of adrenaline on the intensity of emotional experiences. The investigators injected adrenaline into healthy subjects and either informed them correctly or misinformed them about what the side effects of the injected drug might be. Then they exposed the subjects to situations that would provoke annoyance or amusement. The subjects who had been informed correctly about the side effects of the adrenaline injection did not report feeling more emotional than the subjects who had received an injection of a placebo; however, the subjects who had been misinformed reported feeling more emotional, in terms of anger or elation depending on the cognitive circumstances, than did the subjects who been informed correctly about what the drug would do. These findings supported the view that the intensity of emotional experience, whether negative or positive, is greater when people sense physiological activation and do not have an explanation for that activation besides the emotional experience. That is, both physiological arousal and cognitions consonant with an emotion determine together the intensity of experienced emotion.

It would not be a great leap to propose that the more intense an emotional experience, the greater the amount of involuntary, automatic, unconscious augmentation of the behavioral concomitants of that experience. If adrenaline amplified and prolonged rage, for

instance, and rage involuntarily contracted skeletal muscle of the limbs, then adrenaline could augment skeletal muscle contraction and delay the onset of fatigue, even without a direct effect on the skeletal muscle.

A Little Pain Can't Hurt

We all know that emotion-related feats of strength and speed are associated with remarkable loss of the sensation of pain. In scientific jargon this is called “stress-induced analgesia.”

Pain causes adrenaline release from the adrenal gland, as Cannon showed about a century ago. A difficult question—which remains incompletely answered—is what if anything does adrenaline or any other member of its chemical family have to do with the perception of pain?

Adrenaline or norepinephrine may alter the experience of pain by occupying alpha-2 adrenoceptors in the spinal cord. These receptors appear to contribute to a “gate” for transmitting pain impulses up to the brain. The likely source of the chemical transmitter that would occupy these alpha-2 adrenoceptors would not be circulating adrenaline, or even norepinephrine released as a neurotransmitter from sympathetic nerves, but rather norepinephrine released from nerves that descend from locus ceruleus cells in the brainstem. The locus ceruleus, a small cluster of cells in the back of the pons, is the

main source of norepinephrine in the brain. Locus ceruleus cells also send widely ramifying fibers throughout the brain, probably contributing to psychoemotional phenomena such as vigilance and the memory of distressing events.

The main known effectors for pain sensation are endogenous opioids. Behaviors such as exercise increase occupation of opioid receptors in the brain, explaining the sense of elation people feel after a workout. In response to painful stimuli, the brain releases opioids that apparently limit the severity of experienced pain, because blockade of opioid receptors augments the amount of pain for a given amount of stimulation. Because of the augmentation of pain, blockade of opioid receptors also augments the release of adrenaline. Finally, stimulation of the adrenal gland releases not only adrenaline but also endogenous painkiller opiates called enkephalins.

Before dental surgery, dentists often include adrenaline in the local anesthetic, not only because this decreases bleeding but also because it prolongs the anesthesia time. Injection of adrenaline with the local anesthetic always produces large, physiologically active increases in circulating adrenaline levels. Adrenaline injection actually inhibits, rather than augments, responses of circulating levels of the body's opioid, beta-endorphin, in the setting of wisdom tooth extraction. How and why injection of adrenaline would inhibit the opioid response is unknown.